

REAR VIEW

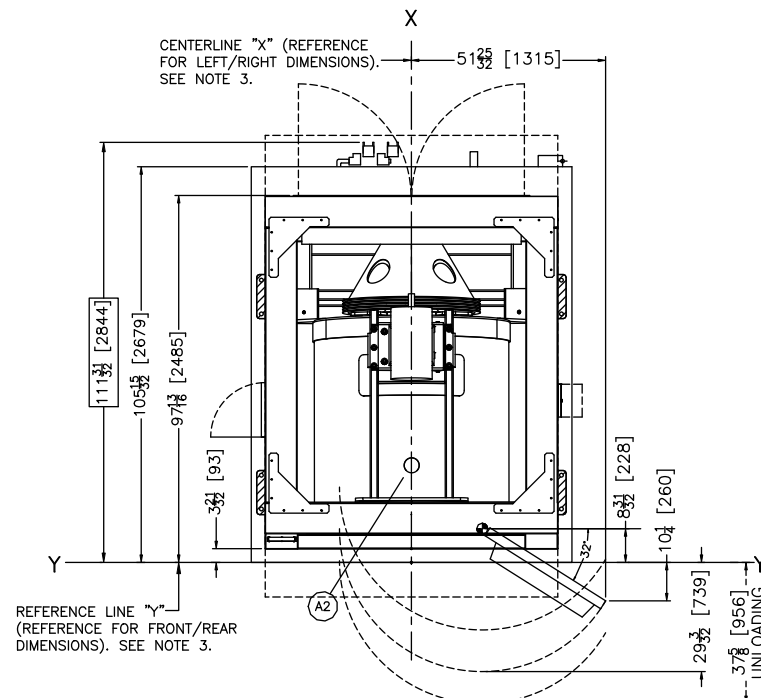

PLAN VIEW

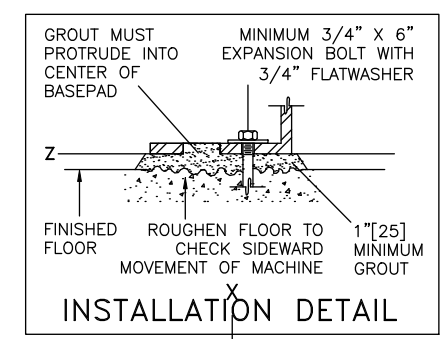

INSTALLATION DETAIL

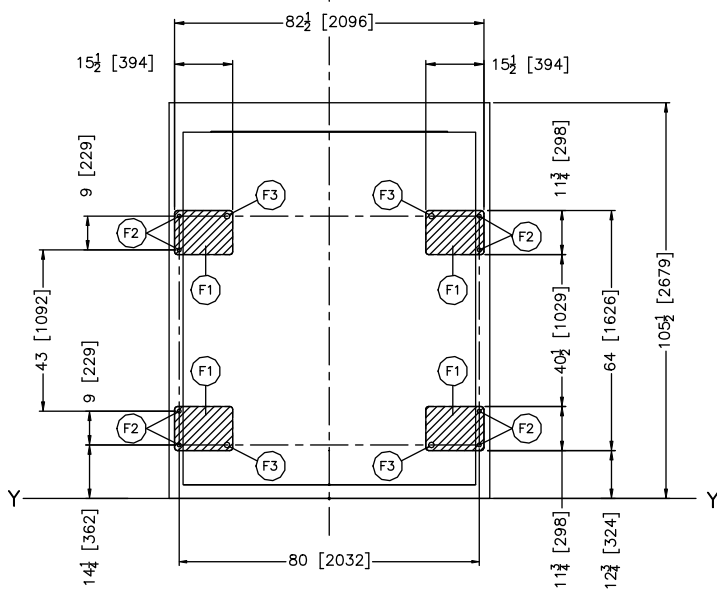

FOUNDATION VIEW

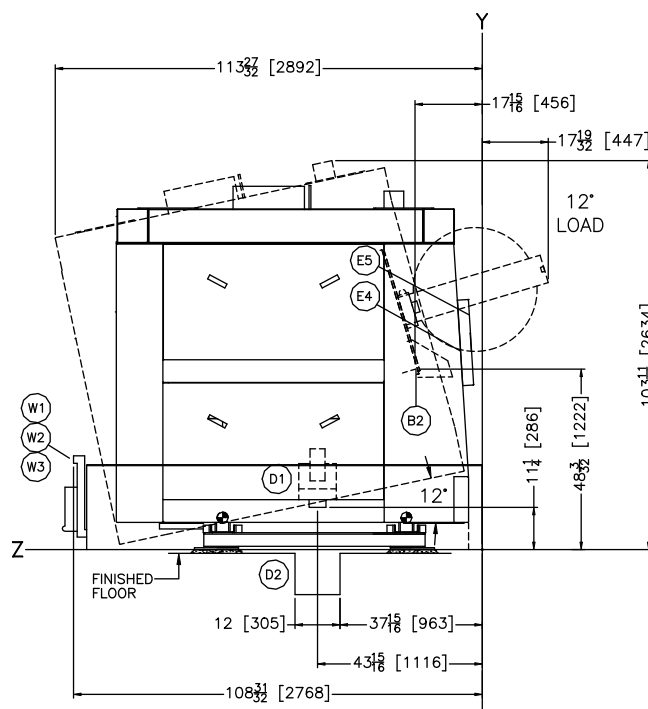

LEFT VIEW

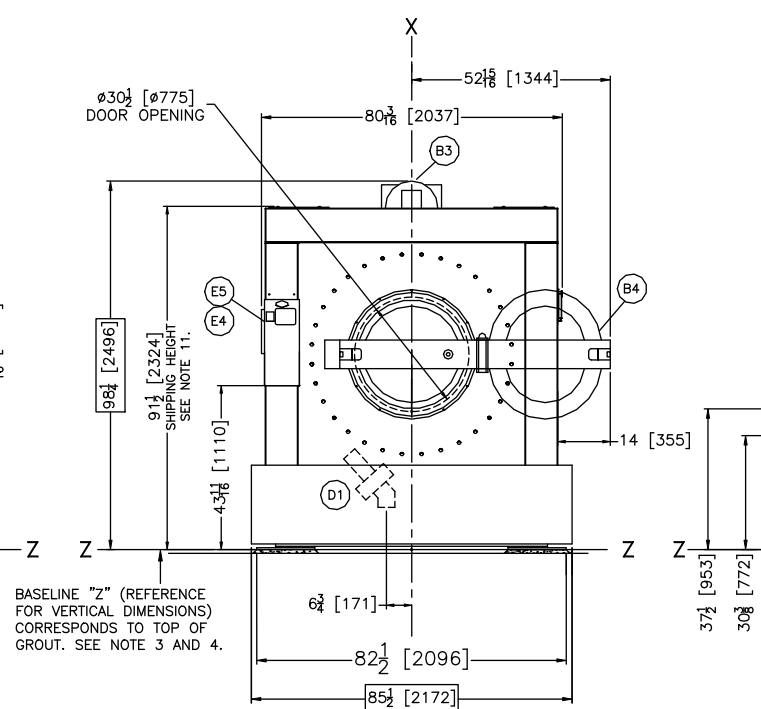

FRONT VIEW

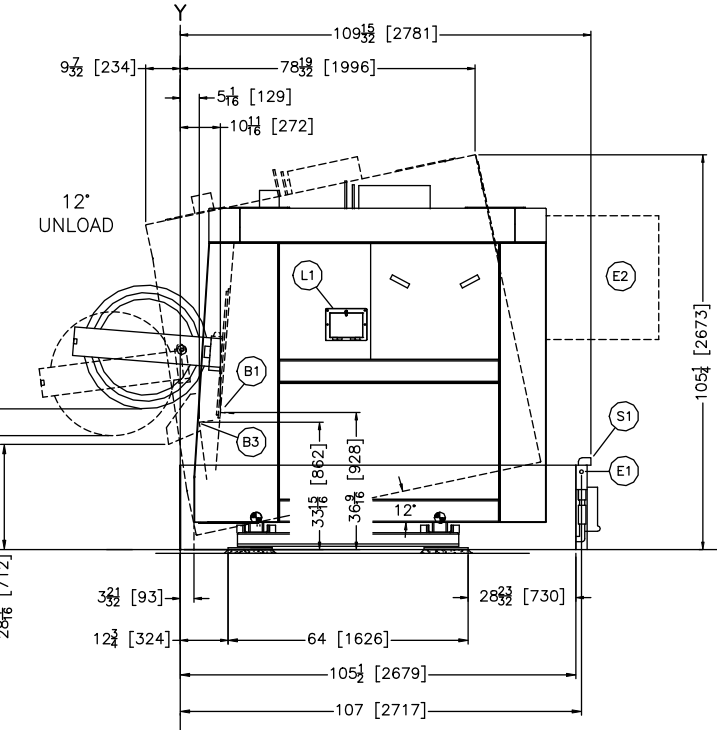

RIGHT VIEW

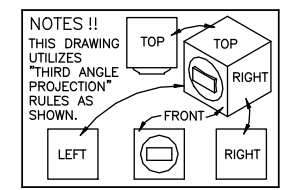

ITEM	LEGEND
W3	OPTIONAL REUSE OR THIRD WATER, 1-1/2" NPT
W2	HOT WATER CONNECTION, 1-1/2" NPT
W1	COLD WATER CONNECTION, 1-1/2" NPT
S1	STEAM INLET, 1-1/4" NPT
L2	STANDARD LIQUID SUPPLY INLETS
L1	SOAP CHUTE
F3	GROUT HOLES
F2	(8) 1-1/16" DIAMETER ANCHOR BOLT HOLES, USE 3/4" X 6" BOLTS MINIMUM. (1) BOLT PER PAD MINIMUM.
F1	BASEPADS, SEE NOTE 8.
E5	MitTouch™ TOUCH SCREEN CONTROLLER, F7D
E4	MICROPROCESSOR CONTROLS, F7B, FLUSH MOUNT
E3	MICROPROCESSOR CONTROL BOX
E2	MAIN ELECTRICAL CONTROL BOXES
E1	MAIN ELECTRICAL CONNECTION
D2	DRAIN TROUGH
D1	DRAIN TO SUMP, 4 1/2" OD, NOT TILTED
B4	DOOR FULLY OPENED
B3	UNLOAD HEIGHT, 12' TILT FORWARD
B2	LOAD HEIGHT, 12' TILT REAR
B1	LOAD HEIGHT, NOT TILTED
A2	VENT, 4" DIAMETER
A1	MAIN AIR CONNECTION, 3/4" NPT

**NOTES**

13 DIMENSIONS ARE VALID FOR A2 MODEL.

12 SHIM TO LEVEL THE MACHINE AND ALLOW FOR 1" [25] MINIMUM GROUT. ANCHOR WITH ONE ANCHOR BOLT PER PAD, MINIMUM. USE 3/4" X 6" BOLTS, MINIMUM. SEE INSTALLATION MAINTENANCE MANUAL FOR FURTHER INSTRUCTIONS.

11 FOR OVERSEAS SHIPMENTS, TO REDUCE THE OVERALL HEIGHT, THE MOTOR MOUNT ASSEMBLY AND VENT PIPE MAY BE REMOVED AND SHIPPED SEPARATELY.

10 DRAIN VALVE MAY MOVE ± 1" [25] IN ANY DIRECTION DURING OPERATION AND MUST NOT BE RIGIDLY CONNECTED TO DRAIN.

9 DUE TO VARYING WEIGHT OF MACHINE ON SPRINGS TOLERANCE IS ± 1/2 [13]. SEE DIMENSIONS WITH ASTERISK [\*] ATTACHED.

8 SHADED AREA DENOTES BASE PADS WHICH MUST BE CONTINUOUSLY SUPPORTED.

7 DO NOT PRE-PIPE ANY CLOSER THAN 60 [1524].

6 AS OF THIS WRITING, THE MINIMUM CLEARANCE REQUIRED BY U.S. NATIONAL ELECTRIC CODES, FROM ELECTRIC BOX TO ANY OBJECT IS:  
 36 [914] IF OBJECT IS AN UNGROUNDED (INSULATED) WALL  
 42 [1067] IF OBJECT IS A GROUNDED WALL (i.e. BARE CONCRETE, BRICK, ETC.)  
 48 [1219] IF OBJECT IS ANY LIVE PART.  
 CHECK LOCAL ELECTRIC CODES FOR FURTHER RESTRICTIONS.

5 CUSTOMER TO SUPPLY CIRCUIT BREAKER OR FUSED BRANCH CIRCUIT DISCONNECT (SAFETY) SWITCHES WITH LAG TYPE FUSES FROM POWER SOURCE TO MACHINE. A SEPARATE GROUND WIRE MUST BE CONNECTED FROM DISCONNECT TO EQUIPMENT.

4 BASELINE "Z" IS THE REFERENCE FOR ALL VERTICAL DIMENSIONS. ON MACHINES WITH FIXED BASE PADS, BASELINE "Z" CORRESPONDS TO THE BOTTOM OF THE BASE PAD. ON MACHINES WITH ADJUSTABLE FEET, BASELINE "Z" CORRESPONDS TO THE BOTTOM OF THE FEET WHEN ADJUSTED SO THAT THE MACHINE IS AT ITS MINIMUM ACCEPTABLE HEIGHT. ON TRAVELING SHUTTLES, BASELINE "Z" CORRESPONDS TO THE BOTTOM RAIL. THE DISTANCE BETWEEN BASELINE "Z" AND THE FINISHED FLOOR WILL VARY AS REQUIRED TO ENSURE BASELINE "Z" IS HORIZONTAL AND ANY INTERFACING MACHINES REQUIRING GROUT ARE SET ON A MINIMUM 1" [25] THICK GROUT BED.

3 USE REFERENCE LINES "X", "Y", AND "Z" TO LOCATE ALL SERVICE CONNECTIONS.

2 NUMBERS IN BRACKETS [ ] DENOTE DIMENSIONS IN MILLIMETERS.

1 ALL DIMENSIONS SHOWN ARE APPROXIMATE, SUBJECT TO NORMAL MANUFACTURING TOLERANCES, AND TO OCCASIONAL CHANGES WITHOUT NOTICE THROUGH REDESIGN AND/OR RELOCATION OF COMPONENTS, ETC. DO NOT USE FOR CONSTRUCTION UNLESS CERTIFIED, AND IN NO EVENT PRE-PIPE CLOSER THAN FIVE FEET FROM MACHINE. FACTORY MUST BE CONSULTED FOR DIMENSIONS IF MACHINE IS TO BE MOVED THROUGH NARROW OR LOW CORRIDORS OR OPENINGS.

**ATTENTION**

MOST REGULATORY AUTHORITIES (INCLUDING OSHA IN THE USA) HOLD THE OWNER/USER ULTIMATELY RESPONSIBLE TO MAINTAIN A SAFE WORKING ENVIRONMENT. ACCORDINGLY, THE OWNER/USER MUST RECOGNIZE ALL FORESEEABLE SAFETY HAZARDS, FURNISH SAFETY INSTRUCTIONS AND GUIDANCE TO ALL PERSONNEL WHO MAY COME IN CONTACT WITH THE INSTALLATION, AND PROVIDE ALL NECESSARY ADDITIONAL SAFETY GUARDS, FENCES, RESTRAINTS, DEVICES, ETC., NOT FURNISHED BY THE EQUIPMENT MANUFACTURER OR VENDOR.

**ATTENTION**

THE FLOOR AND/OR OTHER SUPPORT COMPONENTS MUST HAVE SUFFICIENT STRENGTH (AND RIGIDITY WITH DUE CONSIDERATION FOR NATURAL OR RESONANT FREQUENCY THEREOF) TO WITHSTAND THE FULLY LOADED WEIGHT OF THE MACHINE INCLUDING THE GOODS, THE WATER, AND ANY REPEATED SINUSOIDAL (ROTATING) FORCES GENERATED DURING ITS OPERATION. WRITE THE FACTORY FOR ADDITIONAL MACHINE DATA FOR USE BY A COMPETENT SOIL AND/OR STRUCTURAL ENGINEER.

48040F7B/F7D TILT WASHER EXTR

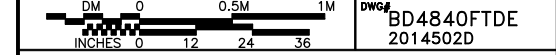

PELLERIN MILNOR CORPORATION  
 P.O. Box 400 Kenner, LA 70063, USA, Phone 504/467-9591,  
 FAX 504/469-1849, Email: milnorinfo@milnor.com