

REAR VIEW

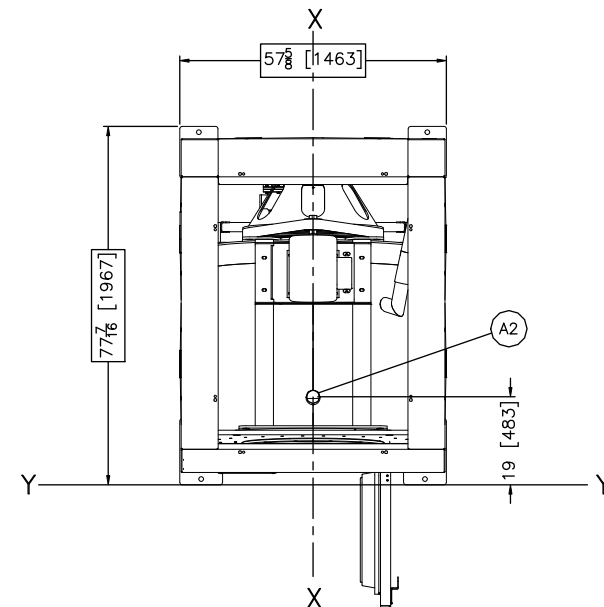

PLAN VIEW

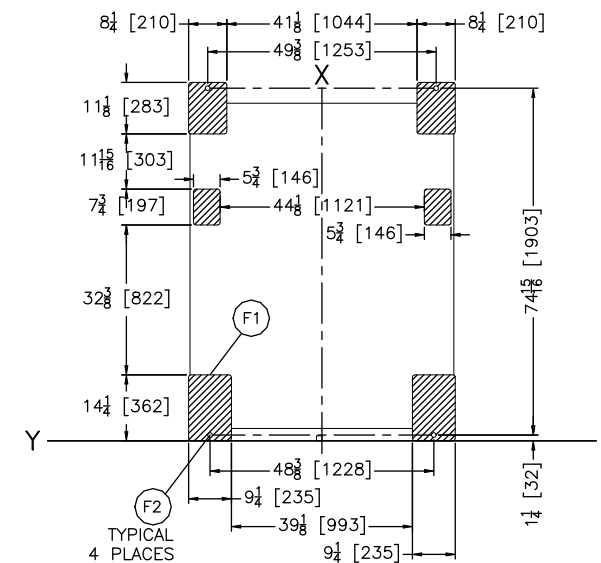

FOUNDATION PLAN

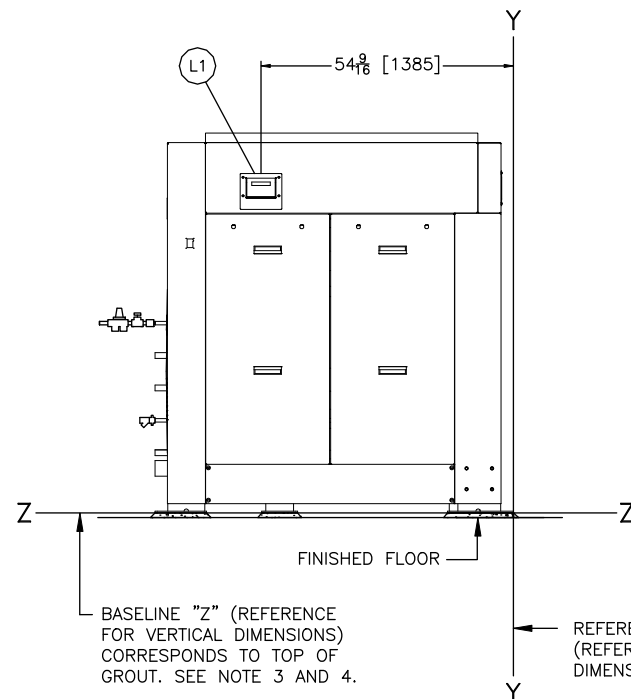

LEFT VIEW

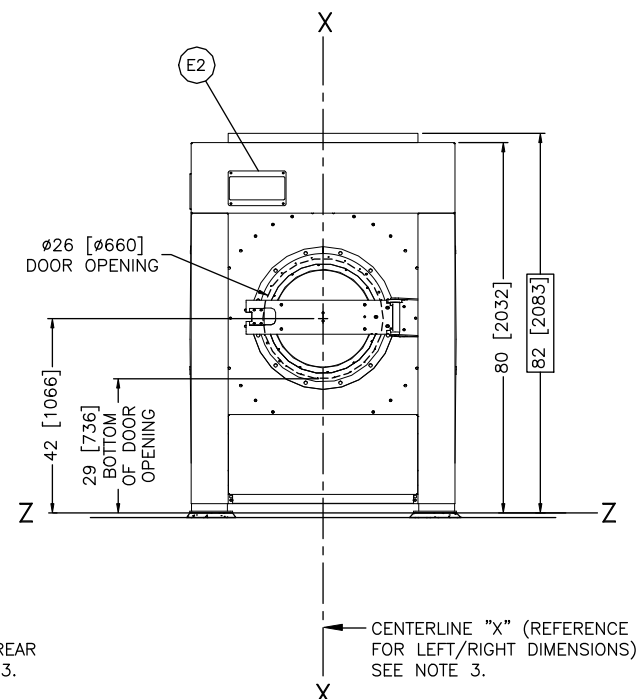

FRONT VIEW

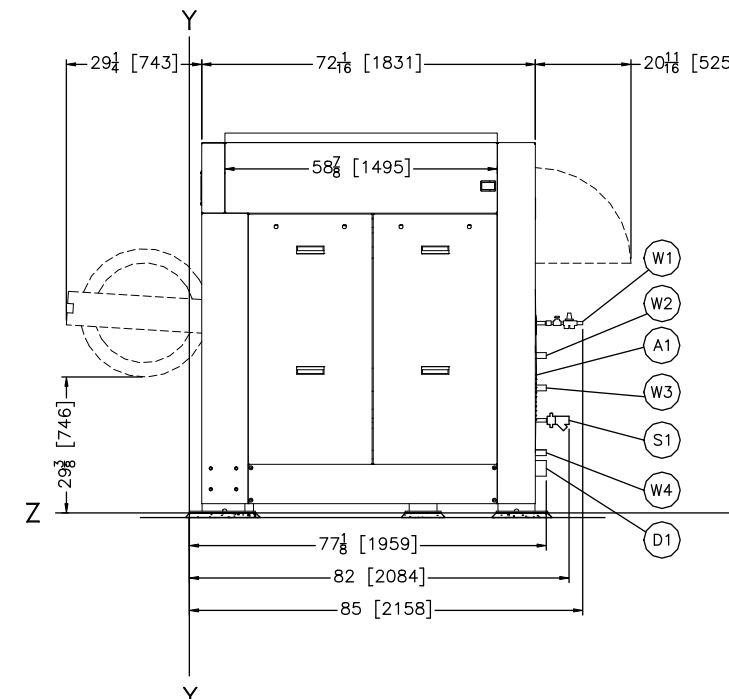

RIGHT VIEW

W4	OPTIONAL THIRD (REUSE) WATER INLET, 1-1/4" NPT CONNECTION
W3	COLD WATER INLET, 1-1/4" NPT CONNECTION
W2	HOT WATER INLET, 1-1/4" NPT CONNECTION
W1	HOT WATER FOR SUPPLY, 3/4" NPT CONNECTION, PRESSURE REGULATOR ASSEMBLY, REMOVED FOR SHIPPING, MUST BE ADDED AT INSTALLATION.
S1	OPTIONAL STEAM INLET, 1/2" NPT CONNECTION, Y-STRAINER, REMOVED FOR SHIPPING, MUST BE ADDED AT INSTALLATION.
L3	ADDITIONAL LIQUID SUPPLY INLETS FOR 15 PORT PERISTALTIC X7W MODELS ONLY.
L2	STANDARD LIQUID SUPPLY INLETS, SEE NOTE 10.
L1	STANDARD SOAP CHUTE
F4	DRAIN HOLES
F3	GROUT HOLES
F2	(4) 1-1/16" DIAMETER ANCHOR BOLT HOLES, USE 5/8" X 6" BOLTS MINIMUM.
F1	BASEPADS, 6 PLACES, SEE NOTE 8.
E3	MICROPROCESSOR CONTROL BOX
E2	MICROPROCESSOR CONTROLS: MWF77J7 USES E-P PLUS® CONTROL; MWF77Z7 USES MitTouch® CONTROL
E1	MAIN ELECTRICAL CONNECTION
D1	DRAIN TO REAR, AIR OPERATED, 3" PIPE SOCKET JOINT
A3	CHEMICAL SUPPLY VENT
A2	VENT, 3" O.D. DIAMETER
A1	MAIN AIR, 1/4" NPT CONNECTION
ITEM	LEGEND

NOTES

- 12 [305] MINIMUM CLEARANCE IS RECOMMENDED FOR SERVICE TO MACHINE ON SIDES NOT REQUIRING OPERATOR ACCESS. 16 [406] MINIMUM IS RECOMMENDED FOR OPERATOR ACCESS TO SOAP SUPPLY. SEE LOCAL ELECTRIC CODES FOR REQUIRED CLEARANCES.
- STANDARD LIQUID SUPPLY INLETS COMES WITH THREE SETS OF FIVE FITTINGS. ONE SET OF 3/8" FITTINGS, ONE SET OF 1/2" FITTINGS, AND ONE SET OF PLUGS WHICH ARE SHIPPED ON MACHINE.
- SHIM TO LEVEL THE MACHINE AND ALLOW FOR 1" [25] MINIMUM GROUT. ANCHOR ALL LABELED ANCHOR BOLT HOLES. USE 5/8" X 6" BOLTS, MINIMUM. SEE INSTALLATION MAINTENANCE MANUAL FOR FURTHER INSTRUCTIONS.
- SHADED AREA DENOTES BASE PADS WHICH MUST BE CONTINUOUSLY SUPPORT.
- DO NOT PRE-PIPE ANY CLOSER THAN 60 [1524].
- AS OF THIS WRITING, THE MINIMUM CLEARANCE REQUIRED BY U.S. NATIONAL ELECTRIC CODES, FROM ELECTRIC BOX TO ANY OBJECT IS:
36 [914] IF OBJECT IS AN UNGROUNDED (INSULATED) WALL.
42 [1067] IF OBJECT IS A GROUNDED WALL (i.e. BARE CONCRETE, BRICK, ETC.)
48 [1219] IF OBJECT IS ANY LIVE PART.
CHECK LOCAL ELECTRIC CODES FOR FURTHER RESTRICTIONS.
- CUSTOMER TO SUPPLY CIRCUIT BREAKER OR FUSED BRANCH CIRCUIT DISCONNECT (SAFETY) SWITCHES WITH LAG TYPE FUSES FROM POWER SOURCE TO MACHINE. A SEPARATE GROUND WIRE MUST BE CONNECTED FROM DISCONNECT TO EQUIPMENT.
- BASELINE "Z" IS THE SAME FOR ALL MILNOR MACHINES AND IS SHOWN ON ALL DIMENSIONAL DRAWINGS. THE DISTANCE BETWEEN BASELINE "Z" AND THE FINISHED FLOOR MAY VARY (WITH CHANGES IN FLOOR HEIGHT) AS REQUIRED TO INSURE THAT BASELINE "Z" IS HORIZONTAL AND ALL COMPONENTS REQUIRING GROUT ARE SET ON A MINIMUM 1" [25] THICK GROUT BED.
- USE REFERENCE LINES "X", "Y", AND "Z" TO LOCATE ALL SERVICE CONNECTIONS.
- NUMBERS IN BRACKETS [] DENOTE DIMENSIONS IN MILLIMETERS.
- ALL DIMENSIONS SHOWN ARE APPROXIMATE, SUBJECT TO NORMAL MANUFACTURING TOLERANCES, AND TO OCCASIONAL CHANGES WITHOUT NOTICE THROUGH REDESIGN AND/OR RELOCATION OF COMPONENTS, ETC. DO NOT USE FOR CONSTRUCTION UNLESS CERTIFIED, AND IN NO EVENT PRE-PIPE CLOSER THAN FIVE FEET FROM MACHINE. FACTORY MUST BE CONSULTED FOR DIMENSIONS IF MACHINE IS TO BE MOVED THROUGH NARROW OR LOW CORRIDORS OR OPENINGS.

ATTENTION

MOST REGULATORY AUTHORITIES (INCLUDING OSHA IN THE USA) HOLD THE OWNER/USER ULTIMATELY RESPONSIBLE TO MAINTAIN A SAFE WORKING ENVIRONMENT. ACCORDINGLY, THE OWNER/USER MUST RECOGNIZE ALL FORESEEABLE SAFETY HAZARDS, FURNISH SAFETY INSTRUCTIONS AND GUIDANCE TO ALL PERSONNEL WHO MAY COME IN CONTACT WITH THE INSTALLATION, AND PROVIDE ALL NECESSARY ADDITIONAL SAFETY GUARDS, FENCES, RESTRAINTS, DEVICES, ETC., NOT FURNISHED BY THE EQUIPMENT MANUFACTURER OR VENDOR.

ATTENTION

THE FLOOR AND/OR OTHER SUPPORT COMPONENTS MUST HAVE SUFFICIENT STRENGTH (AND RIGIDITY WITH DUE CONSIDERATION FOR NATURAL OR RESONANT FREQUENCY THEREOF) TO WITHSTAND THE FULLY LOADED WEIGHT OF THE MACHINE INCLUDING THE GOODS, THE WATER, AND ANY REPEATED SINUSOIDAL (ROTATING) FORCES GENERATED DURING ITS OPERATION. WRITE THE FACTORY FOR ADDITIONAL MACHINE DATA FOR USE BY A COMPETENT SOIL AND/OR STRUCTURAL ENGINEER.

MWF77J7, MWF77Z7

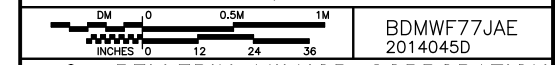

BDMWF77JAE
2014045D
PELLERIN MILNOR CORPORATION
P.O. Box 400 Kenner, LA 70063, USA, Phone 504/467-9591, FAX 504/469-1849, Email: mtg@milnor.com