

FOUNDATION PLAN

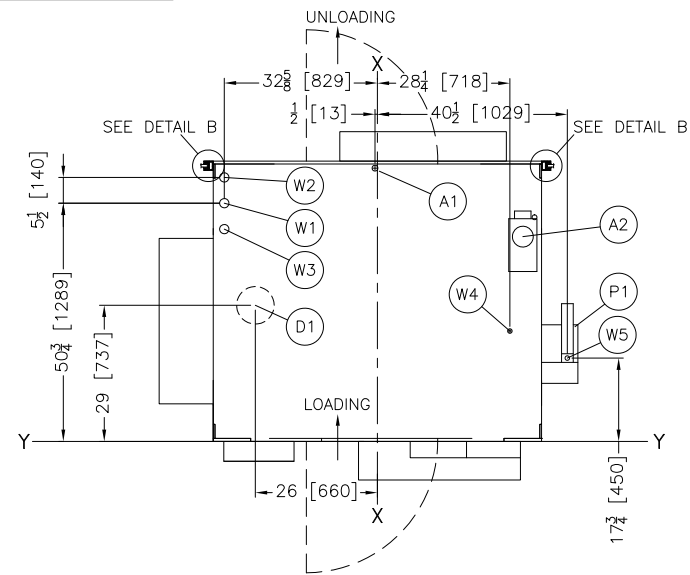

PLAN VIEW

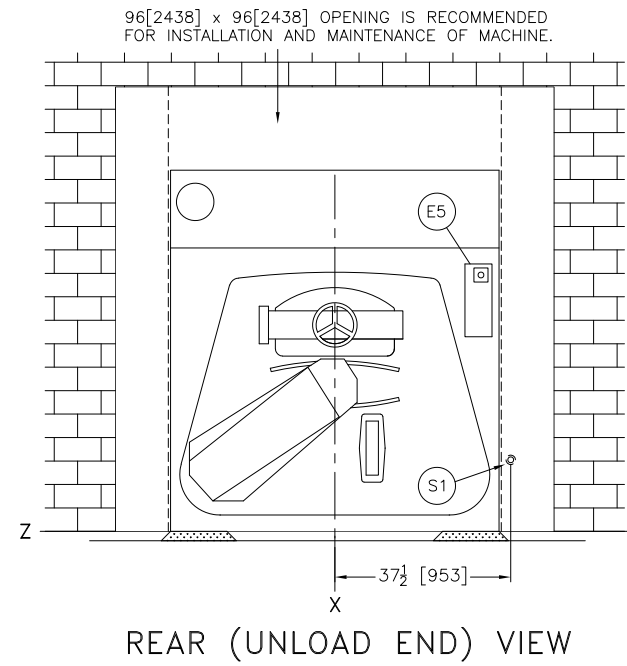

W5	HOT WATER FOR FLUSHING PERISTALTIC, 1/2" NPT.
W4	INDEPENDANT COOLDOWN CONNECTION, 3/4" NPT.
W3	OPTIONAL THIRD WATER INLET CONNECTION, 1 1/2" NPT.
W2	COLD WATER INLET CONNECTION, 1 1/2" NPT.
W1	HOT WATER INLET CONNECTION, 1 1/2" NPT.
S1	STEAM INLET CONNECTION, 1 1/4" NPT.
P2	SOAP CHUTE
P1	PERISTALTIC SUPPLY CONNECTION
M1	SINGLE MOTOR DRIVE
F3	GROUT HOLES, 3" DIAMETER, 1 PER PAD.
F2	(8) 1-1/16" DIAMETER ANCHOR BOLTS HOLES, ANCHOR (1) BOLT PER PAD MINIMUM. 5/8" X 6" BOLTS MINIMUM.
F1	FOUNDATION BASE PADS, 4 PLACES.
E5	REAR CONTROLS
E4	EMERGENCY STOP
E3	MitTouch-EX™ TOUCH SCREEN CONTROLLER
E2	HIGH VOLTAGE CONTROL BOXES
E1	MAIN ELECTRICAL CONNECTION
D1	DRAIN VALVE, 8" DIAMETER. SHOWN IN PUSHED DOWN POSITION. ALSO, SEE NOTES 9 & 10.
A2	STAPHAIRTROL
A1	COMPRESSED AIR INLET CONNECTION, 1/4" NPT.

ITEM LEGEND

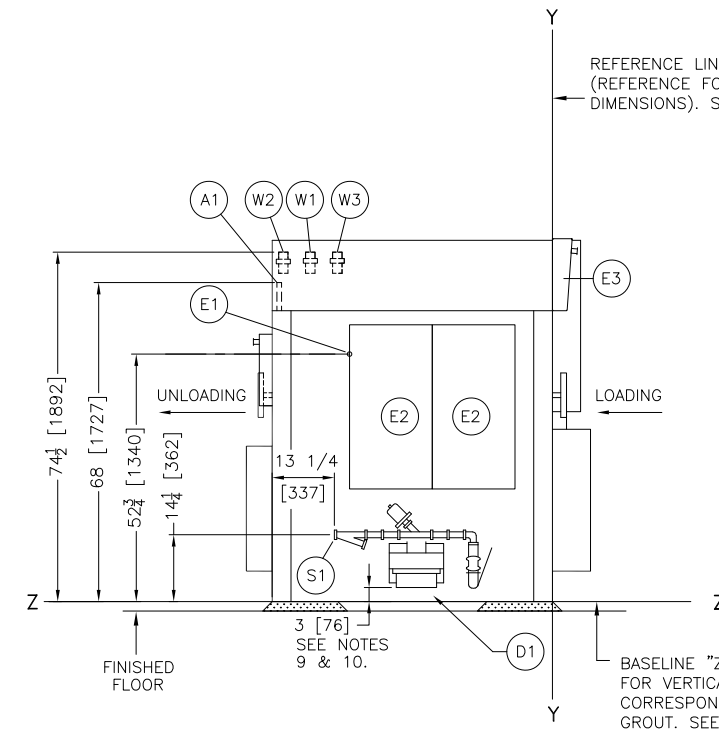

LEFT VIEW

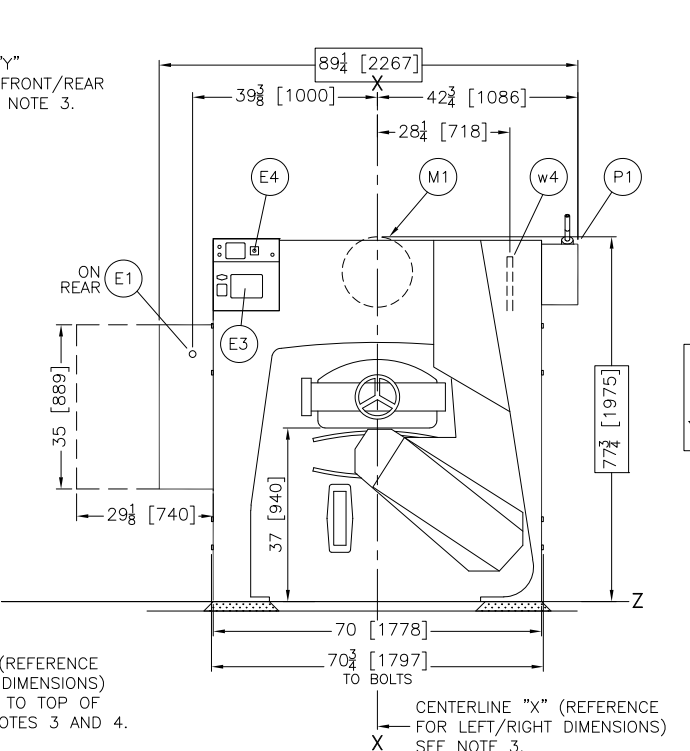

FRONT (LOAD END) VIEW

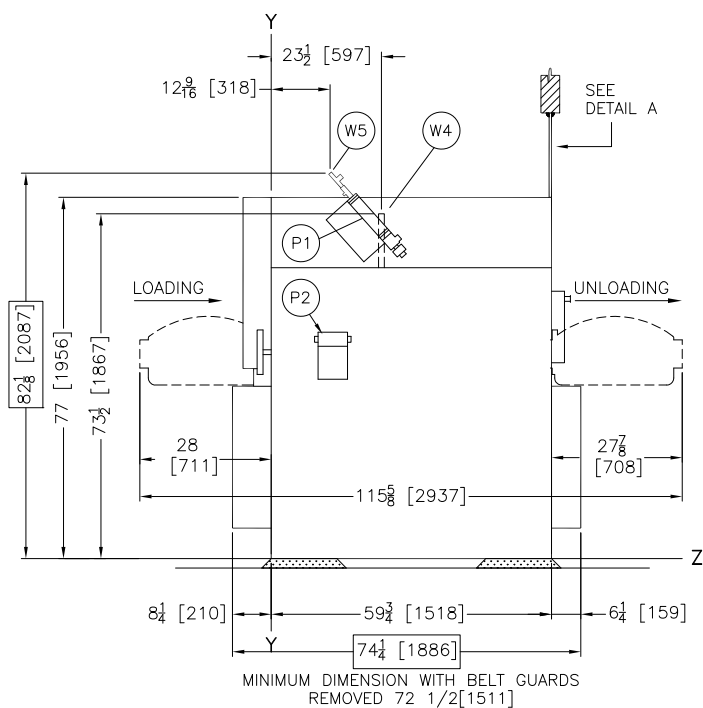

RIGHT VIEW

NOTES

- SHIM TO LEVEL THE MACHINE AND ALLOW FOR 1" [25] MINIMUM GROUT. ANCHOR WITH ONE ANCHOR BOLT PER PAD, MINIMUM. USE 5/8" X 6" BOLTS, MINIMUM. SEE INSTALLATION MAINTENANCE MANUAL FOR FURTHER INSTRUCTIONS.
- ITEMS SHOWN ON THIS PAGE ARE STANDARD OF THIS MACHINE. FOR OPTIONS SEE BD4244SPBB.
- DO NOT PRE-PIPE ANY CLOSER THAN 60 [1524].
- "STEAM HAMMER", CAUSED BY WET STEAM OR CONDENSATION, MAY BE PREVENTED BY INSTALLING A TRAP IMMEDIATELY BEFORE THE STEAM VALVE.
- DRAIN VALVE TO GUTTER PIPING ARRANGEMENT CAN BE REVERSED BY REVERSING DRAIN VALVE AIR CONNECTION. DO NOT CHANGE ANY ELECTRICAL CONNECTIONS.
- THIS DIMENSION IS WITH CYLINDER IN "PUSHED DOWN" POSITION. PUSH DOWN TRAVEL IS APPROXIMATELY 2 1/2 [64].
- DRAIN VALVE MAY MOVE ± 1 1/2 [38] IN ANY DIRECTION DURING OPERATION AND MUST NOT BE RIGIDLY CONNECTED TO DRAIN.
- SHADED AREAS DENOTE BASE PLATES WHICH SHOULD BE CONTINUOUSLY SUPPORTED.
- IT IS NECESSARY TO PUT A 1 [25] THICK BED OF GROUT BENEATH THIS MACHINE TO INSURE THE STAPH-GUARD BRAKE ASSEMBLY WILL NOT HIT THE FLOOR.
- AS OF THIS WRITING, THE MINIMUM CLEARANCE REQUIRED BY U.S. NATIONAL ELECTRIC CODES, FROM ELECTRIC BOX TO ANY OBJECT IS:  
36 [914] IF OBJECT IS AN UNGROUNDED (INSULATED) WALL.  
42 [1067] IF OBJECT IS A GROUNDED WALL (ie. BARE CONCRETE, BRICK, ETC.)  
48 [1219] IF OBJECT IS ANY LIVE PART.  
CHECK LOCAL ELECTRIC CODES FOR FURTHER RESTRICTIONS.
- CUSTOMER TO SUPPLY CIRCUIT BREAKER OR FUSED BRANCH CIRCUIT DISCONNECT (SAFETY) SWITCHES WITH LAG TYPE FUSES FROM POWER SOURCE TO MACHINE. A SEPARATE GROUND WIRE MUST BE CONNECTED FROM DISCONNECT TO EQUIPMENT.
- BASELINE "Z" IS THE SAME FOR ALL MILNOR MACHINES AND IS SHOWN ON ALL DIMENSIONAL DRAWINGS. THE DISTANCE BETWEEN BASELINE "Z" AND THE FINISHED FLOOR MAY VARY (WITH CHANGES IN FLOOR HEIGHT) AS REQUIRED TO INSURE THAT BASELINE "Z" IS HORIZONTAL AND ALL COMPONENTS REQUIRING GROUT ARE SET ON A MINIMUM 1" [25] THICK GROUT BED.
- USE REFERENCE LINES "X", "Y", AND "Z" TO LOCATE ALL SERVICE CONNECTIONS.
- NUMBERS IN BRACKETS [ ] DENOTE DIMENSIONS IN MILLIMETERS.
- ALL DIMENSIONS SHOWN ARE APPROXIMATE, SUBJECT TO NORMAL MANUFACTURING TOLERANCES, AND TO OCCASIONAL CHANGES WITHOUT NOTICE THROUGH REDESIGN AND/OR RELOCATION OF COMPONENTS, ETC. DO NOT USE FOR CONSTRUCTION UNLESS CERTIFIED, AND IN NO EVENT PRE-PIPE CLOSER THAN FIVE FEET FROM MACHINE. FACTORY MUST BE CONSULTED FOR DIMENSIONS IF MACHINE IS TO BE MOVED THROUGH NARROW OR LOW CORRIDORS OR OPENINGS.

**ATTENTION**  
MOST REGULATORY AUTHORITIES (INCLUDING OSHA IN THE USA) HOLD THE OWNER/USER ULTIMATELY RESPONSIBLE TO MAINTAIN A SAFE WORKING ENVIRONMENT. ACCORDINGLY, THE OWNER/USER MUST RECOGNIZE ALL FORESEEABLE SAFETY HAZARDS, FURNISH SAFETY INSTRUCTIONS AND GUIDANCE TO ALL PERSONNEL WHO MAY COME IN CONTACT WITH THE INSTALLATION, AND PROVIDE ALL NECESSARY ADDITIONAL SAFETY GUARDS, FENCES, RESTRAINTS, DEVICES, ETC., NOT FURNISHED BY THE EQUIPMENT MANUFACTURER OR VENDOR.

**ATTENTION**  
THE FLOOR AND/OR OTHER SUPPORT COMPONENTS MUST HAVE SUFFICIENT STRENGTH (AND RIGIDITY WITH DUE CONSIDERATION FOR NATURAL OR RESONANT FREQUENCY THEREOF) TO WITHSTAND THE FULLY LOADED WEIGHT OF THE MACHINE INCLUDING THE GOODS, THE WATER, AND ANY REPEATED SINUSOIDAL (ROTATING) FORCES GENERATED DURING ITS OPERATION. WRITE THE FACTORY FOR ADDITIONAL MACHINE DATA FOR USE BY A COMPETENT SOIL AND/OR STRUCTURAL ENGINEER.

42044SR2/SR3 SM  
  
 DWG# BD4244SPCE 2020442D  
  
 PELLERIN MILNOR CORPORATION  
 P.O. Box 400 Kenner, LA 70063, USA, Phone 504/467-9591, FAX 504/468-3094, Email: milnorinfo@milnor.com