

OPTIONAL DUAL DRAIN

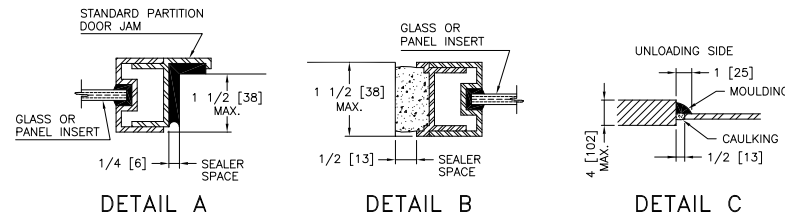

DETAIL A

DETAIL B

DETAIL C

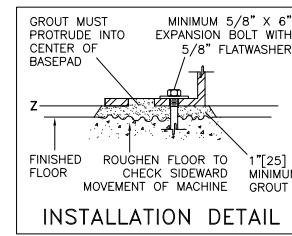

INSTALLATION DETAIL

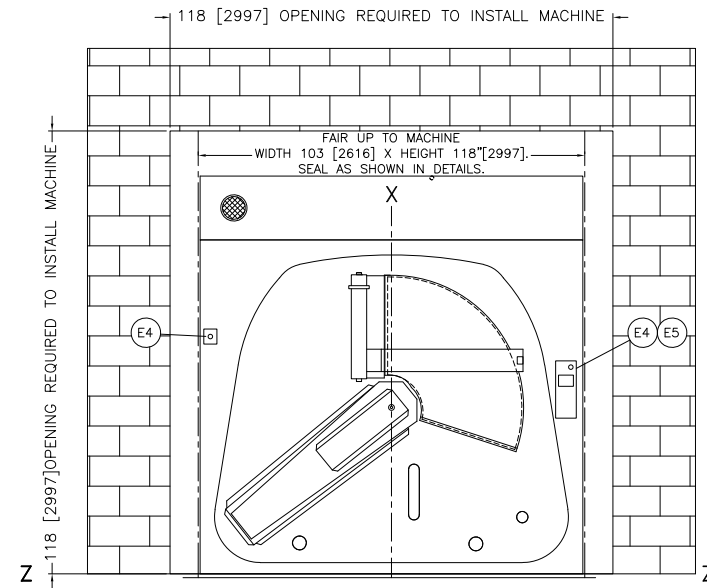
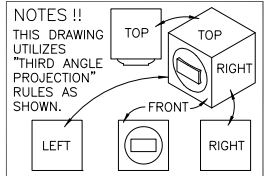

REAR VIEW
CLEAN SIDE

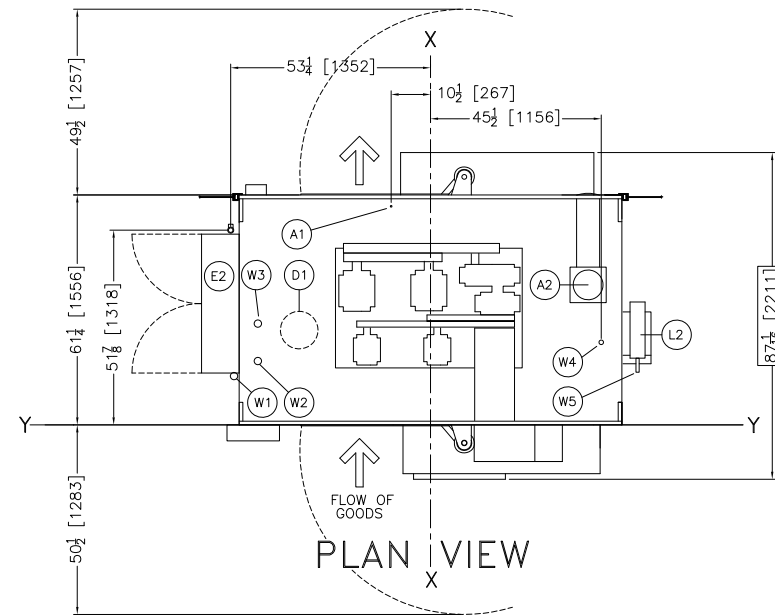

PLAN VIEW

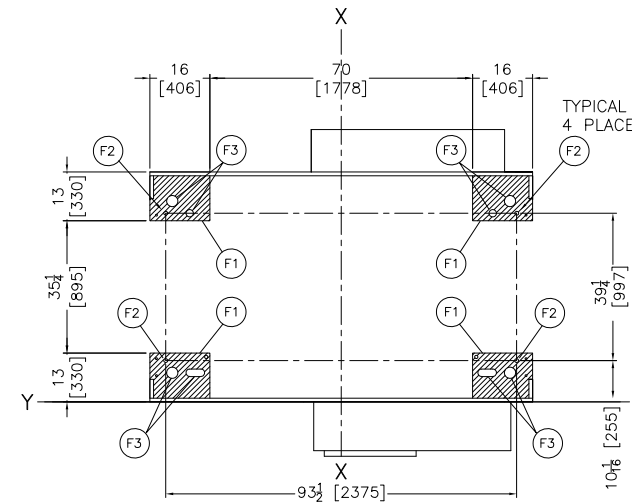

FOUNDATION
PLAN VIEW

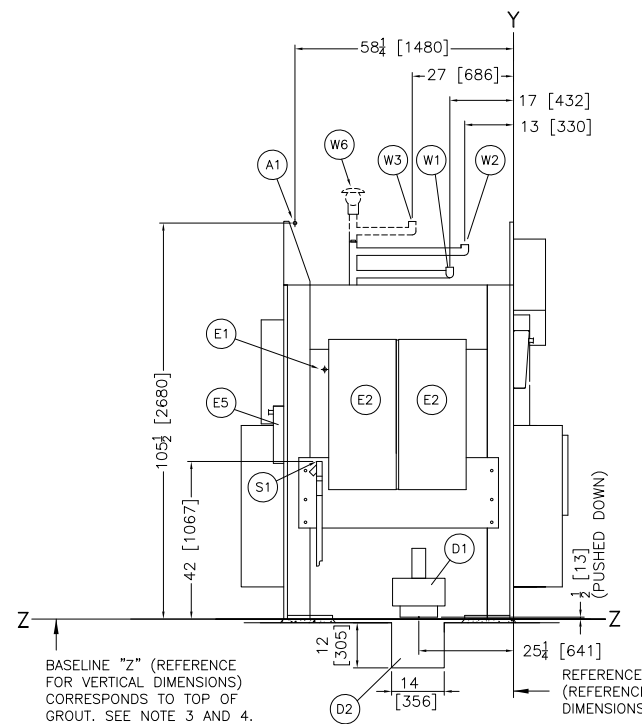

LEFT VIEW Y

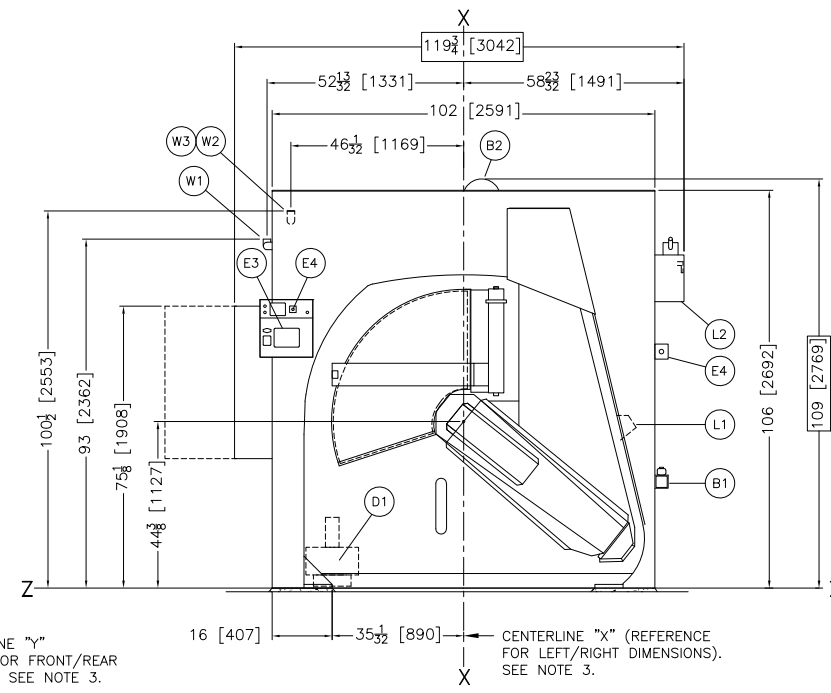

FRONT VIEW
SOIL SIDE

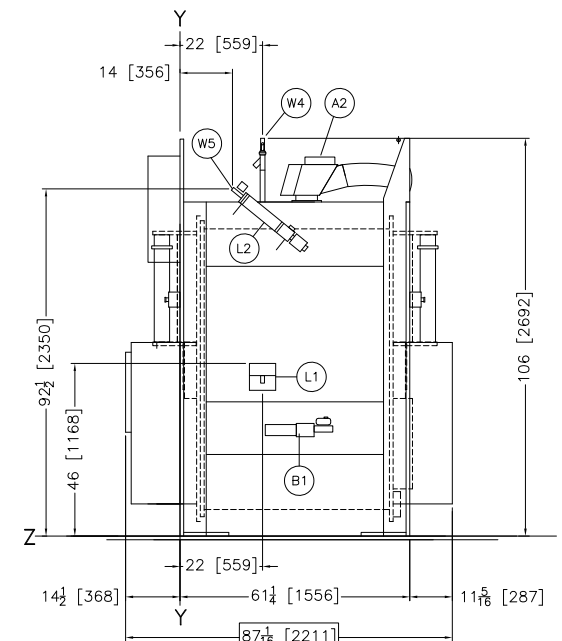

RIGHT VIEW

W6	OPTIONAL VACUUM BREAKER
W5	HOT WATER INLET FOR PERISTALTIC 1/2" NPT
W4	COOLDOWN INLET 1" NPT CONNECTION
W3	THIRD WATER INLET CONNECTION 2" NPT, OPTIONAL
W2	COLD WATER INLET CONNECTION 2" NPT
W1	HOT WATER INLET CONNECTION 2" NPT
S1	STEAM CONNECTION 1 1/4" NPT
L2	PERISTALTIC SUPPLY
L1	SOAP CHUTE
F3	GROUT HOLES
F2	1 1/16" DIAMETER ANCHOR BOLT HOLES, USE 5/8" x 6" BOLTS MINIMUM. (1) BOLT PER PAD MINIMUM.
F1	FOUNDATION BASE PADS, 4 PLACES
E5	REAR CONTROLS
E4	EMERGENCY STOP
E3	MitTouch-EX™ TOUCH SCREEN CONTROLLER
E2	HIGH VOLTAGE CONTROL BOXES
E1	MAIN ELECTRICAL CONNECTION
D2	OPTIONAL DUAL DRAIN TROUGHS
D3	OPTIONAL DUAL DRAINS, 10" DIAMETER
D1	STANDARD DRAIN, 10" DIAMETER
B2	AUTOSPOT MOTOR
B1	BRAKE AIR CYLINDER
A2	STAPHAIRTROL, VENT 8" [203]
A1	COMPRESSED AIR INLET 1/4" NPT
ITEM	LEGEND

- NOTES**
- SHIM TO LEVEL THE MACHINE AND ALLOW FOR 1" [25] MINIMUM GROUT. ANCHOR WITH ONE ANCHOR BOLT PER PAD. MINIMUM USE 5/8" x 6" BOLTS. MINIMUM. SEE INSTALLATION MAINTENANCE MANUAL FOR FURTHER INSTRUCTIONS.
 - "STEAM HAMMER", CAUSED BY WET STEAM OR CONDENSATION, MAY BE PREVENTED BY INSTALLING A TRAP IMMEDIATELY BEFORE THE STEAM VALVE.
 - DRAIN VALVE MAY MOVE ± 1-1/2 [38] IN ANY DIRECTION DURING OPERATION AND MUST NOT BE RIGIDLY CONNECTED TO DRAIN.
 - SHADED AREA ARE BASE PLATES WHICH MUST BE CONTINUOUSLY SUPPORTED ON 1" [25] THICK GROUT. ALSO, THIS 1" [25] OF GROUT IS NECESSARY TO INSURE THE STAPH GUARD BRAKE WILL NOT HIT THE FLOOR.
 - AS OF THIS WRITING, THE MINIMUM CLEARANCE REQUIRED BY U.S. NATIONAL ELECTRIC CODES, FROM ELECTRIC BOX TO ANY OBJECT IS:
36 [914] IF OBJECT IS AN UNGROUNDED (INSULATED) WALL.
42 [1067] IF OBJECT IS A GROUNDED WALL (ie. BARE CONCRETE, BRICK, ETC.)
48 [1219] IF OBJECT IS ANY LIVE PART.
CHECK LOCAL ELECTRIC CODES FOR FURTHER RESTRICTIONS.
 - CUSTOMER TO SUPPLY CIRCUIT BREAKER OR FUSED BRANCH CIRCUIT DISCONNECT (SAFETY) SWITCHES WITH LAG TYPE FUSES FROM POWER SOURCE TO MACHINE. A SEPARATE GROUND WIRE MUST BE CONNECTED FROM DISCONNECT TO EQUIPMENT.
 - BASELINE "Z" IS THE SAME FOR ALL MILNOR MACHINES AND IS SHOWN ON ALL DIMENSIONAL DRAWINGS. THE DISTANCE BETWEEN BASELINE "Z" AND THE FINISHED FLOOR MAY VARY (WITH CHANGES IN FLOOR HEIGHT) AS REQUIRED TO INSURE THAT BASELINE "Z" IS HORIZONTAL AND ALL COMPONENTS REQUIRING GROUT ARE SET ON A MINIMUM 1" [25] THICK GROUT BED.
 - USE REFERENCE LINES "X", "Y", AND "Z" TO LOCATE ALL SERVICE CONNECTIONS.
 - NUMBERS IN BRACKETS [] DENOTE DIMENSIONS IN MILLIMETERS.
 - ALL DIMENSIONS SHOWN ARE APPROXIMATE, SUBJECT TO NORMAL MANUFACTURING TOLERANCES, AND TO OCCASIONAL CHANGES WITHOUT NOTICE THROUGH REDESIGN AND/OR RELOCATION OF COMPONENTS, ETC. DO NOT USE FOR CONSTRUCTION UNLESS CERTIFIED, AND IN NO EVENT PRE-PIPE CLOSER THAN FIVE FEET FROM MACHINE. FACTORY MUST BE CONSULTED FOR DIMENSIONS IF MACHINE IS TO BE MOVED THROUGH NARROW OR LOW CORRIDORS OR OPENINGS.
- ATTENTION**
MOST REGULATORY AUTHORITIES (INCLUDING OSHA IN THE USA) HOLD THE OWNER/USER ULTIMATELY RESPONSIBLE TO MAINTAIN A SAFE WORKING ENVIRONMENT. ACCORDINGLY, THE OWNER/USER MUST RECOGNIZE ALL FORESEEABLE SAFETY HAZARDS, FURNISH SAFETY INSTRUCTIONS AND GUIDANCE TO ALL PERSONNEL WHO MAY COME IN CONTACT WITH THE INSTALLATION, AND PROVIDE ALL NECESSARY ADDITIONAL SAFETY GUARDS, FENCES, RESTRAINTS, DEVICES, ETC., NOT FURNISHED BY THE EQUIPMENT MANUFACTURER OR VENDOR.
- ATTENTION**
THE FLOOR AND/OR OTHER SUPPORT COMPONENTS MUST HAVE SUFFICIENT STRENGTH (AND RIGIDITY WITH DUE CONSIDERATION FOR NATURAL OR RESONANT FREQUENCY THEREOF) TO WITHSTAND THE FULLY LOADED WEIGHT OF THE MACHINE INCLUDING THE GOODS, THE WATER, AND ANY REPEATED SINUSOIDAL (ROTATING) FORCES GENERATED DURING ITS OPERATION. WRITE THE FACTORY FOR ADDITIONAL MACHINE DATA FOR USE BY A COMPETENT SOIL AND/OR STRUCTURAL ENGINEER.

72044SR2/SR3

DM 0 0.5M 1M
INCHES 0 12 24 36

DWG# BD7244SPBE
2017355D

MILNOR PELLERIN MILNOR CORPORATION
P.O. Box 400 Kenner, LA 70063, USA, Phone 504/467-9591,
FAX 504/469-1849, Email: milnorinfo@milnor.com