

STARTER TRAC

PRODUCT NUMBER	DIMENSION DESCRIPTION	PIECES PER BOX
ST-50	CAN BE USED AS STARTER TRAC OR CASING BEAD. FRONT RETURN IS 3/4" WITH STRIATIONS AND PERFORATIONS FOR POSITIVE BONDING OF BASE TO FOAM BOARD. THERE IS NO DRIP EDGE. IDEAL FOR USE WHERE FINISHED EDGE IS EXPOSED. 3" WIDE NAILING FLANGE.	35
ST-58		35

10' LENGTHS - ADD SUFFIX "WP" TO ORDER WITH WEEP HOLES; EXAMPLE STWP-50.

APPLICATION: ST-50, ST-58
EXCELLENT CAULK AND PAINT ADHESION, HOLES ON RETURN FLANGE ALLOW FOR BASE COAT TO BOND TO SURFACE OF SUBSTRATE.

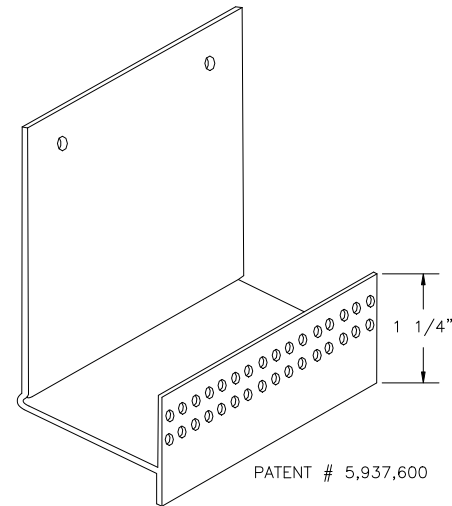
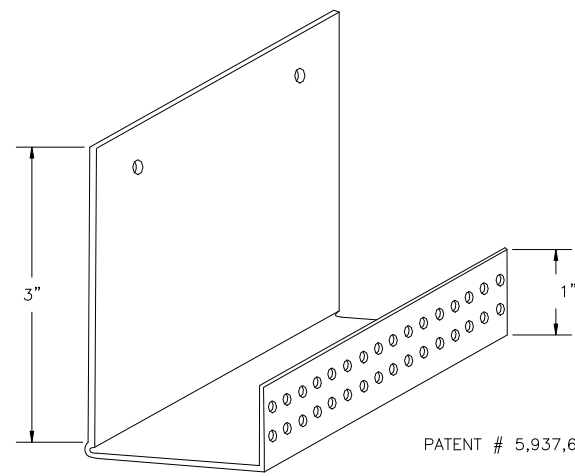

STARTER TRAC DRIP EDGE

PRODUCT NUMBER	DIMENSION DESCRIPTION	PIECES PER BOX
STDE-50	STARTER TRAC WITH DRIP EDGE. STRIATIONS ON FRONT RETURN, AND PERFORATIONS ENSURE POSITIVE PHYSICAL BOND OF THE BASE COAT TO THE FOAM BOARD. EXTRA WIDE 3" NAILING FLANGE. BASE SHELF HAS WEEP HOLES 3" O.C. TO ALLOW WATER TO MIGRATE FROM THE SYSTEM.	35
STDE-58		35

10' LENGTHS

APPLICATION: STDE-50, STDE-58
EXCELLENT CAULK AND PAINT ADHESION, HOLES ON RETURN FLANGE ALLOW FOR BASE COAT TO BOND TO SURFACE OF SUBSTRATE.

