

CORNER BEAD

PRODUCT NUMBER	DIMENSIONS/DESCRIPTIONS	PIECES PER BOX
209	DRYWALL CORNER BEAD 1 1/4" X 1 1/4" FLANGE	100

8' & 10' LENGTHS

APPLICATION: 209
TO BE USED ON ALL OUTSIDE CORNERS. RUST AND IMPACT RESISTANT. TAPERED LEGS ARE PERFORATED AND STRIATED FOR BETTER ADHESION; ELIMINATES THE NEED TO TAPE THE FLANGE. PREVENTS ELECTROLYSIS. 8' & 10' LENGTHS

SPECIFICATION:
CORNER BEAD SHALL BE PLASTIC COMPONENTS, INC. # 209. ALL DRYWALL ACCESSORIES SHALL CONFORM TO ASTM STANDARDS D3678-97 AND C1047-99 AND D4216-99. FINISH COMPATIBLE WITH DRYWALL MUD AND ALL PAINT FINISHES. THEY SHALL BE USED WHERE SPECIFIED BY THE ARCHITECT AND INSTALLED PER INDUSTRY STANDARDS AND MANUFACTURER'S INSTRUCTIONS.

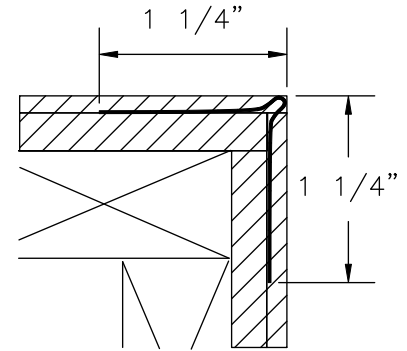
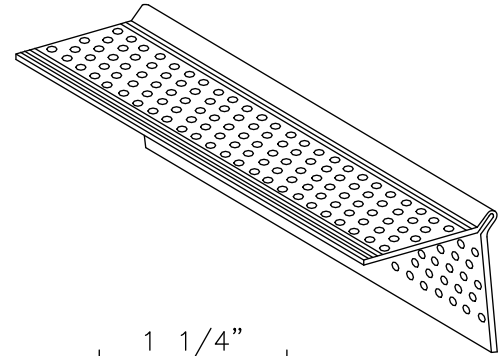

ARCH CORNER BEAD

PRODUCT NUMBER	DIMENSIONS/DESCRIPTIONS	PIECES PER BOX
209A	DRYWALL CORNER BEAD 1 1/4" X 1 1/4" FLANGE ONE FLANGE SLOTTED.	100

8' & 10' LENGTHS

APPLICATION: 209A
TO BE USED WHERE A CURVE OR ARCH IS FORMED. PRE-SLOTTED FLANGE ALLOWS FOR PERFECT ARCHES. TAPERED FLANGES ARE PERFORATED AND STRIATED FOR BETTER ADHESION; ELIMINATES THE NEED TO TAPE THE FLANGE. 8' & 10' LENGTHS

SPECIFICATION:
ARCH BEAD SHALL BE PLASTIC COMPONENTS, INC. # 209A. ALL DRYWALL ACCESSORIES SHALL CONFORM TO ASTM STANDARDS D3678-97 AND C1047-99 AND D4216-99. FINISH COMPATIBLE WITH DRYWALL MUD AND ALL PAINT FINISHES. THEY SHALL BE USED WHERE SPECIFIED BY THE ARCHITECT AND INSTALLED PER INDUSTRY STANDARDS AND MANUFACTURER'S INSTRUCTIONS

