

Extreme Moisture STARTER TRAC®

PRODUCT NUMBER	DESCRIPTION	DIMENSION A	PIECES PER BOX
SB-EMT75	3" (76mm) BACK FLANGE	3/4" (19mm)	30
SB-EMT1		1" (25mm)	30
SB-EMT15		1-1/2" (38mm)	30
SB-EMT2		2" (51mm)	30

10' (3m) Lengths

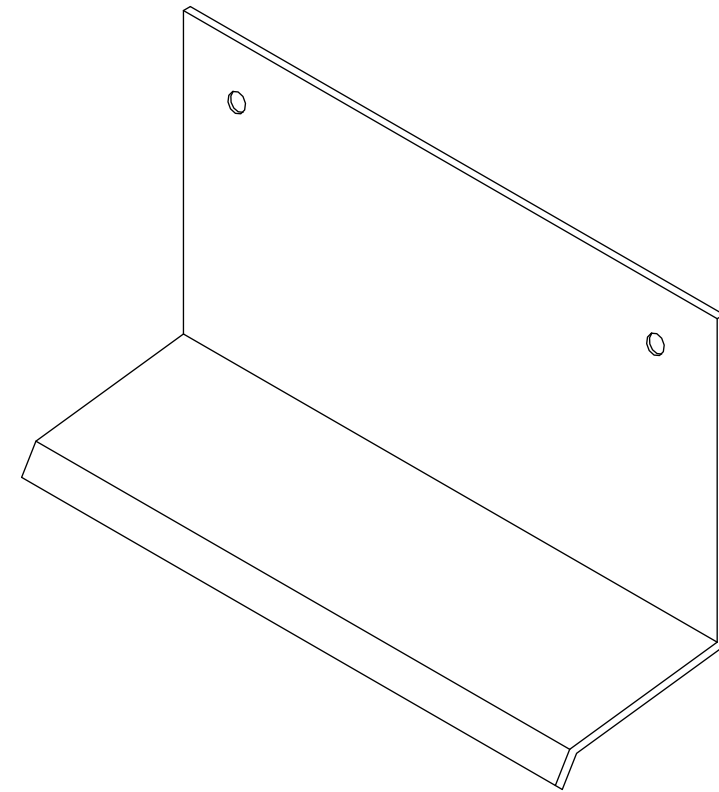

APPLICATION:

PLASTIC COMPONENTS' SB-EMT STARTER TRACK™, IS THE PVC TRIM TO CHOOSE FOR EXTREME MOISTURE CONDITIONS. FOR USE AT THE BASE OF A WALL, THIS NEW STARTER TRAC HAS A 3" (89mm) BACK FLANGE AND SLOPED FRONT EDGE TO MOVE MOISTURE OUT AND AWAY FROM THE WALL ASSEMBLY.

SPECIFICATION:

WINDOW/DOOR DRIP EDGE WILL BE PLASTIC COMPONENTS INC. #_____. ALL EXTERIOR ACCESSORIES SHALL CONFORM TO ASTM STANDARDS D1784, C1063 AND D4216. ALL PRODUCTS SHALL BE THIRD PARTY TESTED TO MEET ASTM STANDARD D4216 AND BE CANADIAN CODE COMPLIANT. THEY SHALL BE USED WHERE SPECIFIED BY THE ARCHITECT AND INSTALLED PER INDUSTRY STANDARDS.

