

ISSUE NO.	REV. LET.	ISSUES OR REVISIONS	DATE	BY	APP.
1					

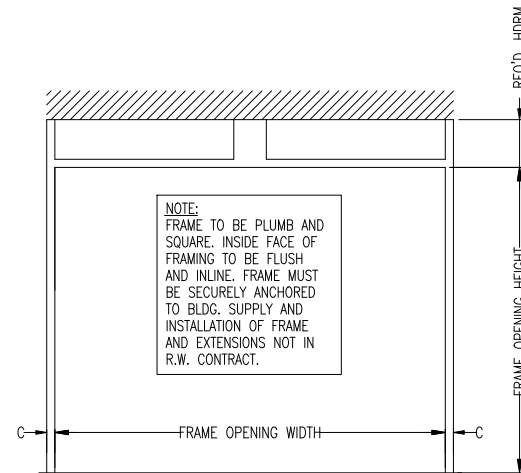

INTERIOR ELEVATION OF FRAMING BY OTHERS

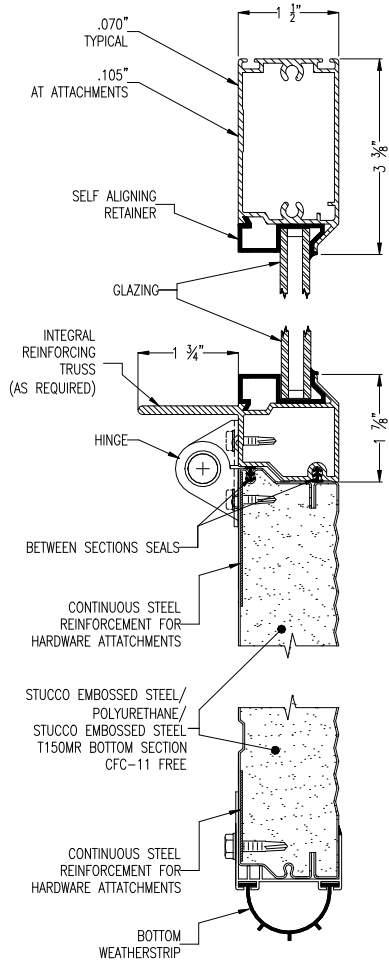
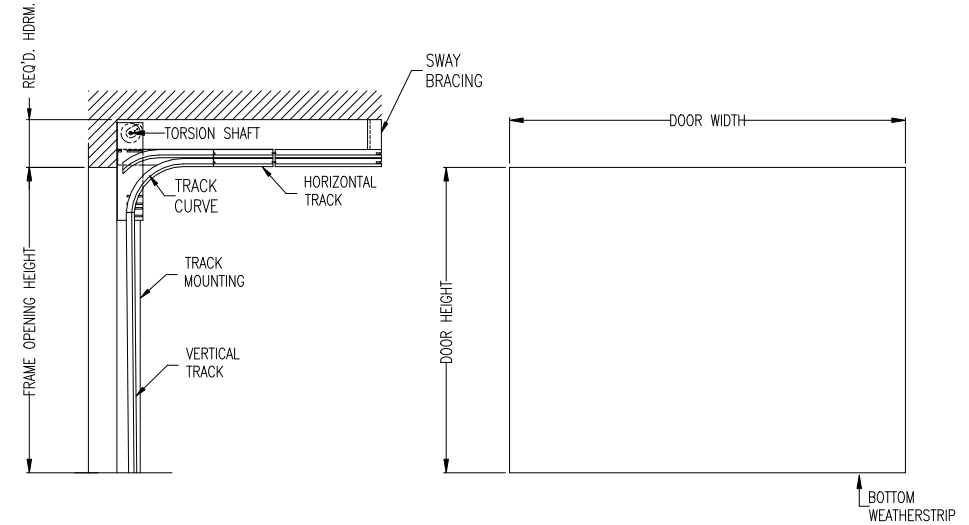

CROSS SECTION

EXTERIOR ELEVATION

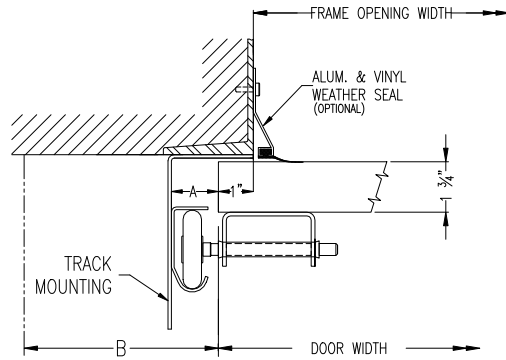

STEEL JAMB DETAILS

DOOR WIDTH		ADCA	A	B	C	TRUSSING	WIND LOAD
DOOR HEIGHT		2"	1 1/2"	3 1/2"	2 1/2"		
FRAME OPENING WIDTH		3"	2"	4"	3"	OPTIONS	
FRAME OPENING HEIGHT		VERTICAL TRACK					
HEADROOM REQ'D.		HORIZONTAL TRACK					
TRACK MOUNTING	<input type="checkbox"/> ADCA <input type="checkbox"/> BRACKET	LITES					

TITLE ALUMATITE A150T DOOR C/W ___" LOW HEADROOM FRONT MOUNT HARDWARE

CLIENT _____

SETS REQUIRED _____ TAG _____

CLIENT'S ORDER NO. _____ R-W ORDER NO. _____

Richards-Wilcox CANADA INC. TORONTO, ONTARIO	DRAWN		SCALE	NTS
	CHECKED		DRAWING NO.	
	APPROVED		SHEET NO.	