

ISSUE NO.	REV. LET.	ISSUES OR REVISIONS	DATE	BY	APP.
1					

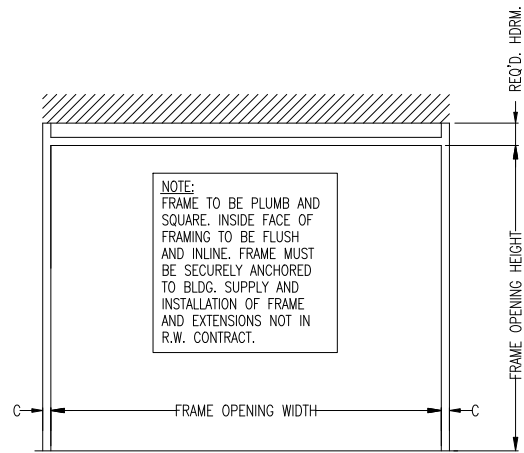

INTERIOR ELEVATION OF FRAMING BY OTHERS

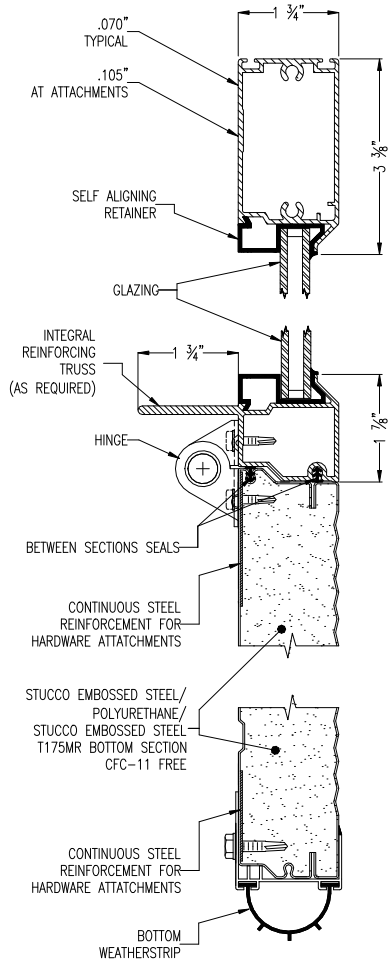
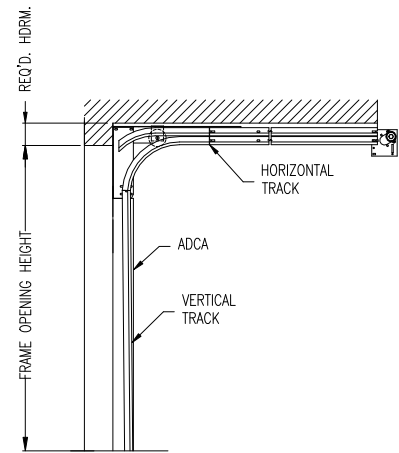

CROSS SECTION

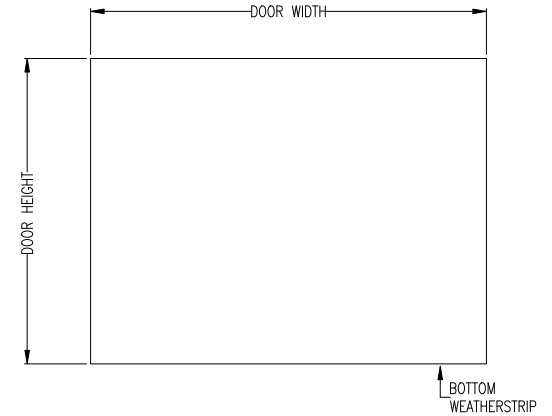

EXTERIOR ELEVATION

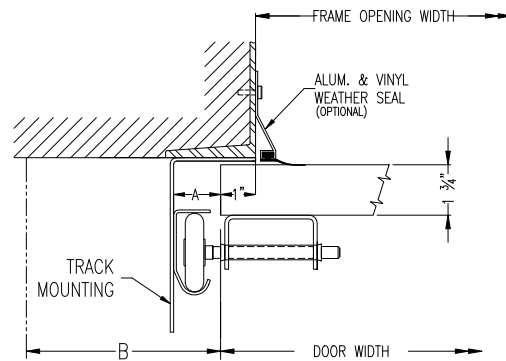

STEEL JAMB DETAILS

DOOR WIDTH	
DOOR HEIGHT	
FRAME OPENING WIDTH	
FRAME OPENING HEIGHT	
HEADROOM REQ'D.	
TRACK MOUNTING	<input type="checkbox"/> ADCA <input type="checkbox"/> BRACKET

ADCA	A	B	C
2"	1 1/2"	3 1/2"	2 1/2"
3"	2"	4"	3"
VERTICAL TRACK			
HORIZONTAL TRACK			
LITES			

TRUSSING	WIND LOAD
OPTIONS	

TITLE	ALUMATITE A175T DOOR C/W ___" LOW HEADROOM REAR MOUNT HARDWARE				
CLIENT					
SETS REQUIRED	TAG				
CLIENT'S ORDER NO.	R-W ORDER NO.				

Richards-Wilcox

CANADA INC.
TORONTO, ONTARIO

DRAWN			SCALE	NTS
CHECKED			DRAWING NO.	
APPROVED			SHEET NO.	