

# MOUNTING BRACKET OPTIONS

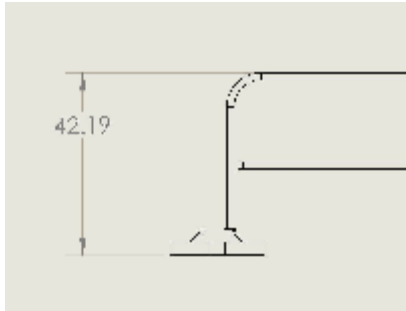

1. MOBILE BASE  
PART NUMBER 420068

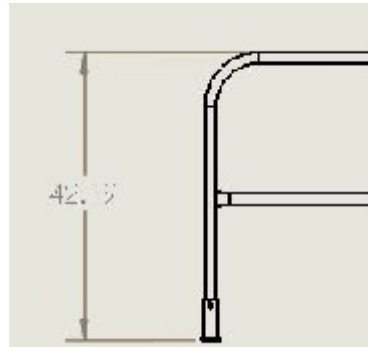

PERMANENT MOUNT BRACKET  
SINGLE  
2. PART NUMBER 400033

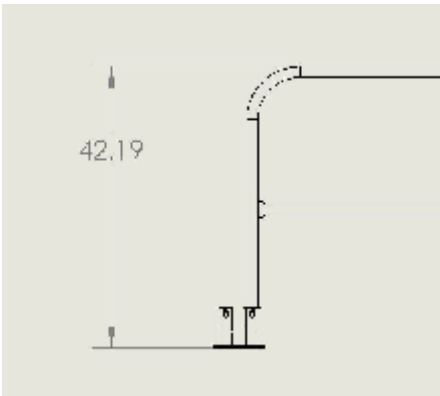

PERMANENT MOUNT BRACKET  
DOUBLE  
3. PART NUMBER 400035

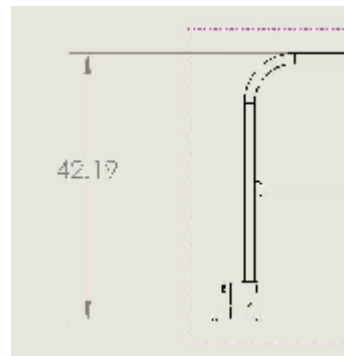

PERMANENT MOUNT BRACKET  
CORNER  
4. PART NUMBER 400037

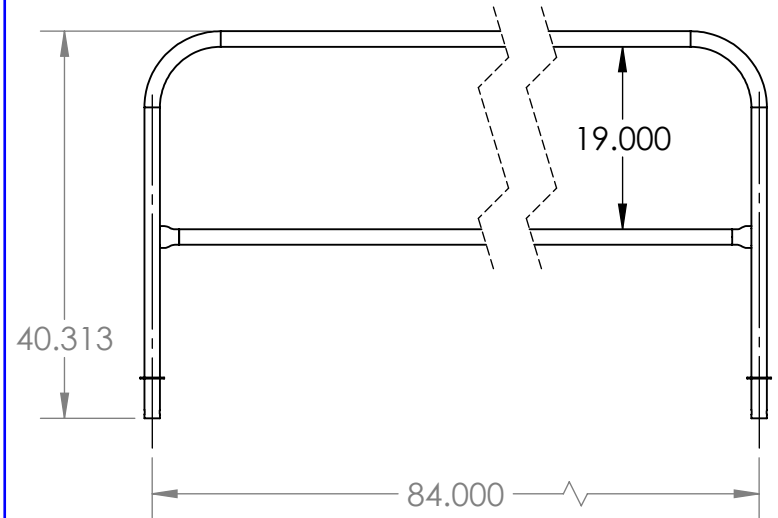

**PROPRIETARY AND CONFIDENTIAL**  
THE INFORMATION CONTAINED IN THIS DRAWING IS THE SOLE PROPERTY OF SAFETY RAIL COMPANY. ANY REPRODUCTION IN PART OR AS A WHOLE WITHOUT THE WRITTEN PERMISSION OF SAFETY RAIL COMPANY, IS PROHIBITED.

		UNLESS OTHERWISE SPECIFIED:	NAME	DATE
		DIMENSIONS ARE IN INCHES	DRAWN	TN 06/26/14
		TOLERANCES:	CHECKED	
		FRACTIONAL ±	ENG APPR.	
		ANGULAR: MACH ± BEND ±	MFG APPR.	
		TWO PLACE DECIMAL ±	Q.A.	
		THREE PLACE DECIMAL ±	COMMENTS:	
		INTERPRET GEOMETRIC TOLERANCING PER:	SRC STANDARDS:	
		MATERIAL	AWS D1.3	
NEXT ASSY	USED ON	FINISH	Use only ER70S-6 wire.	
		PCOAT AERO YEL	75/25 Mig Gas	
APPLICATION		DO NOT SCALE DRAWING		

TITLE:		
<b>7' RAIL</b>		
SIZE	DWG. NO.	REV
<b>A</b>	<b>400006A</b>	
SCALE: 1:20 WEIGHT: 20.57 LBSHEET 1 OF 1		