

MOUNTING BRACKET OPTIONS

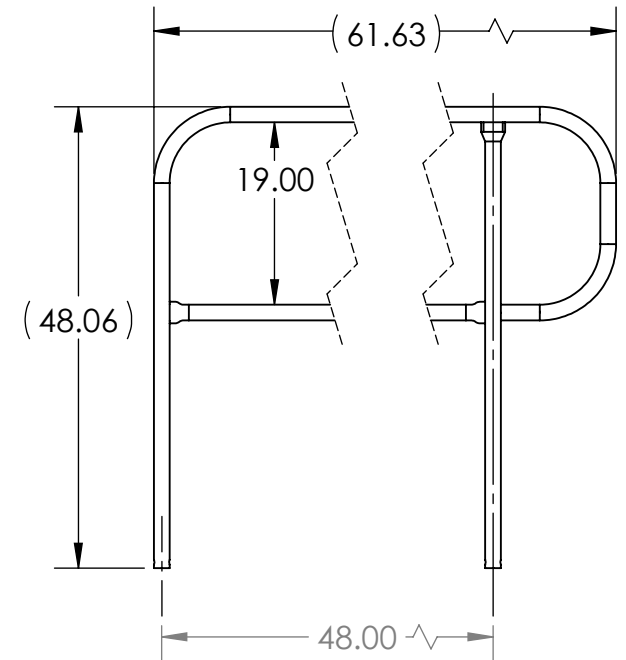

1. FACEMOUNT BRACKET SINGLE
PART NUMBER 400036

2. FACEMOUNT BRACKET DOUBLE
PART NUMBER 400016

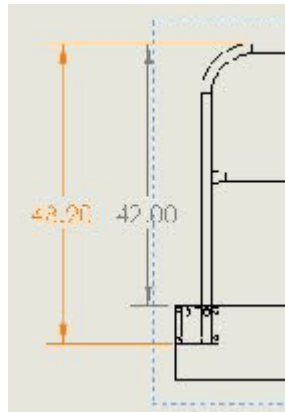
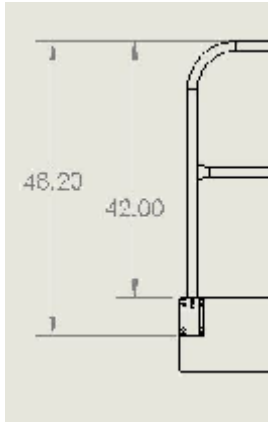
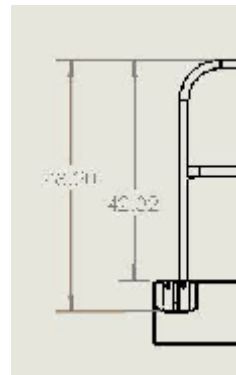
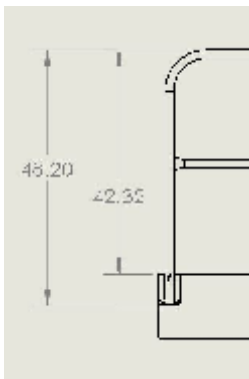

3. FLUSHMOUNT BRACKET SINGLE
PART NUMBER 400055

4. FLUSHMOUNT BRACKET DOUBLE
PART NUMBER 400028

PROPRIETARY AND CONFIDENTIAL
THE INFORMATION CONTAINED IN THIS DRAWING IS THE SOLE PROPERTY OF SAFETY RAIL COMPANY LLC. ANY REPRODUCTION IN PART OR AS A WHOLE WITHOUT THE WRITTEN PERMISSION OF SAFETY RAIL COMPANY LLC IS PROHIBITED.

			UNLESS OTHERWISE SPECIFIED:		NAME	DATE
			DIMENSIONS ARE IN INCHES	DRAWN	GHJ	5/8/2017
			TOLERANCES:	CHECKED		
			FRACTIONAL ±	ENG APPR.		
			ANGULAR: MACH ± BEND ±	MFG APPR.		
			TWO PLACE DECIMAL ±	Q.A.		
			THREE PLACE DECIMAL ±	COMMENTS:		
			INTERPRET GEOMETRIC TOLERANCING PER:			
			MATERIAL			
	NEXT ASSY	USED ON	FINISH			
			PCOAT SAFETY YEL			
	APPLICATION		DO NOT SCALE DRAWING			

TITLE:		
5' FINISH PIT RAIL		
SIZE	DWG. NO.	REV
A	400248A	
SCALE: 1:20	WEIGHT:	SHEET 1 OF 1