

SECTIONAL VIEW - ORION17 MRL-4254 (1L)

PLAN VIEW - ORION17 MRL-4254 (1L) 2 SPEED WITTUR DOORS

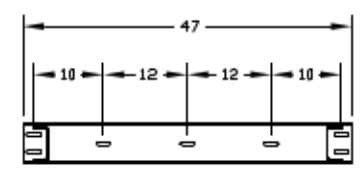
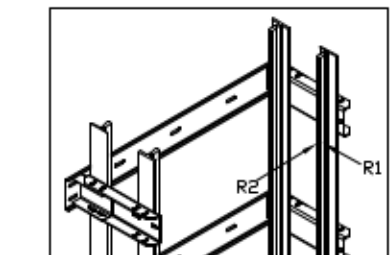
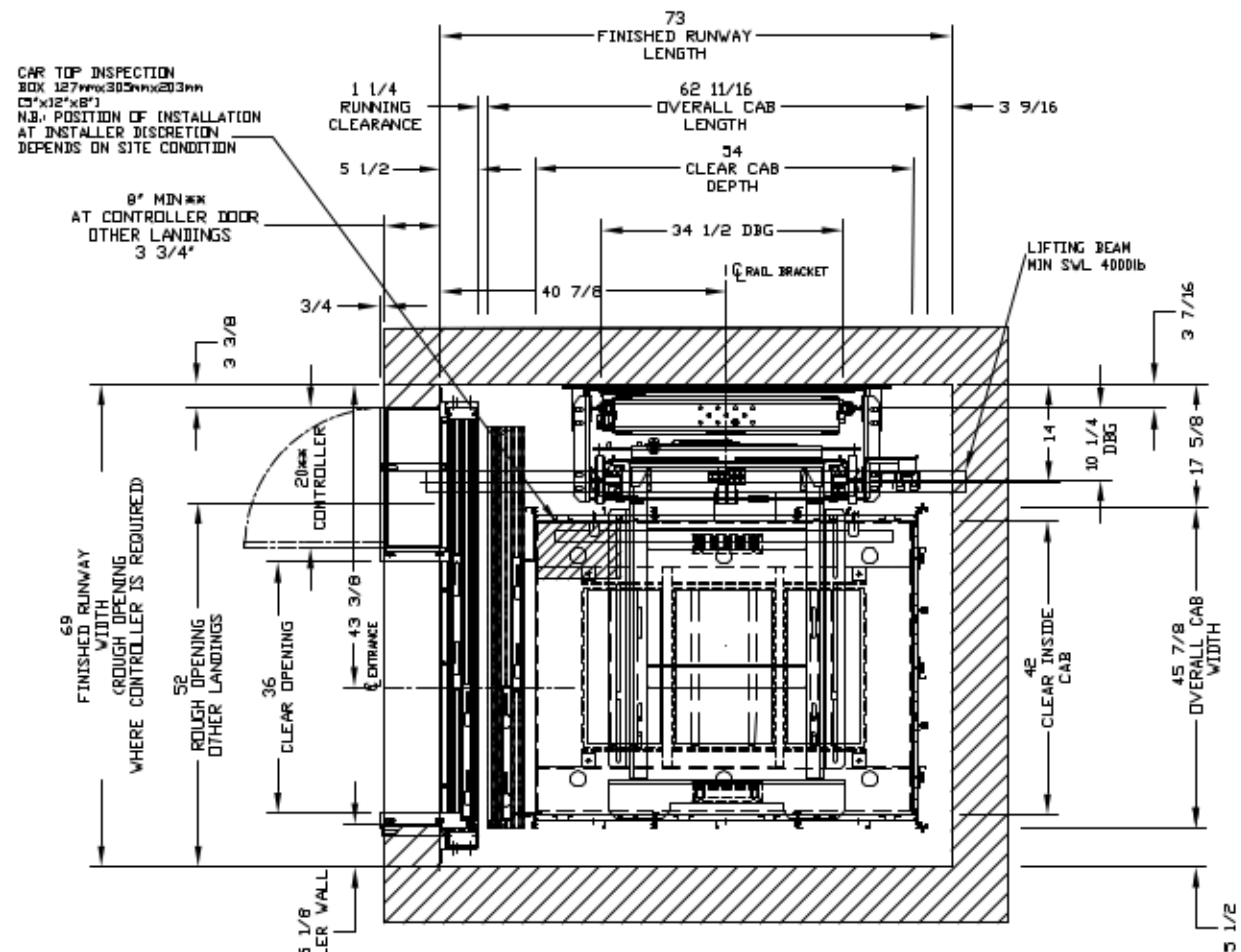
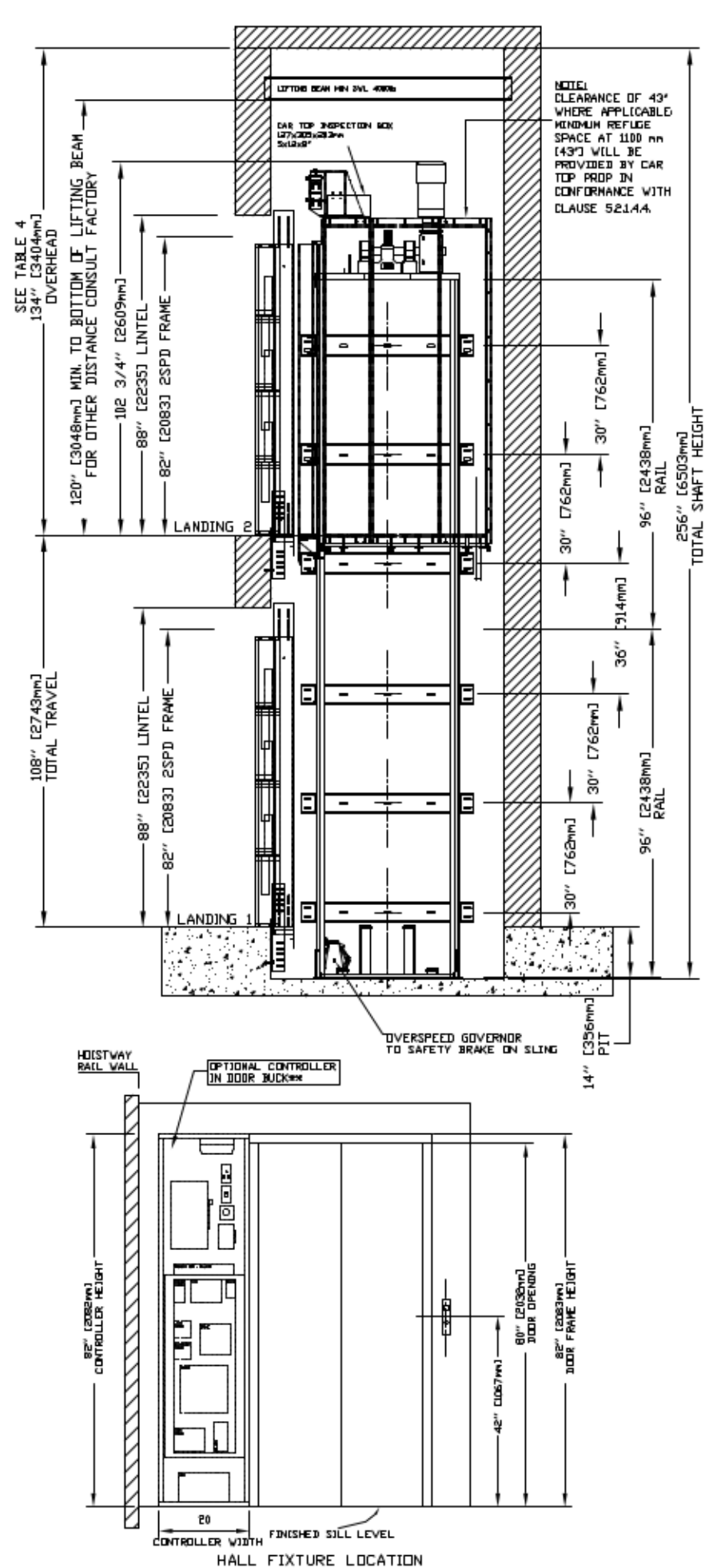

RAIL BRACKETS

TABLE 1
RAIL FORCES

*R1	*R2
500 lbf	1570 lbf
RAIL WEIGHT	80 lbs / ft

FOR TOTAL PULL-OUT FORCE ON RAIL BRACKET,
Eq. 2 x 720 = 1440 lbf
FOR LOCAL APPLICATION OF PIT LOAD,
R1 MUST BE DOUBLED.

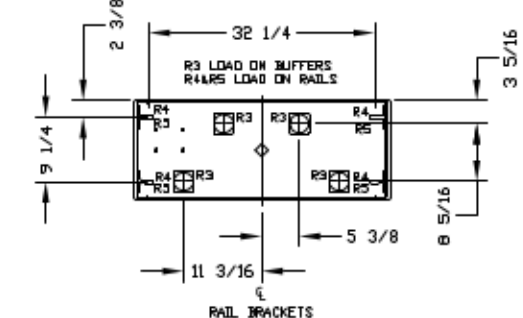

TABLE 2
LOADS ON PIT

PIT RE-ACTION FORCE	
R3	8000 LBS
R4	3000 LBS
R5	9500 LBS

NOTE A**
OPTIONAL DOOR BUCK CONTROLLER (DBC) SHOWN FOR REFERENCE. WHERE DBC IS NOT USED A DEDICATED MACHINE ROOM MUST BE PROVIDED BY OTHERS.

NOTE B
WHERE SMOKE DETECTORS ARE REQUIRED, WIRING FROM A NORMALLY CLOSED CONTACT AT BOTH THE DESIGNATED RETURN LANDINGS, SMOKE DETECTORS AND ALTERNATE RETURN LANDING SMOKE DETECTOR SHALL BE PROVIDED TO THE CONTROLLER. A NORMALLY CLOSED CONTACT REPRESENTING ALL OTHER SMOKE DETECTORS MUST BE PROVIDED TO THE CONTROLLER.

NOTE C
ALL INFORMATION IS SUBJECT TO CHANGE.
PLEASE REFERENCE OUR ON-LINE DRAWINGS AT
WWW.SAVARIA.COM FOR THE MOST RECENT UPDATES

PROVISIONS BY OTHERS

*GENERAL
HOISTWAY- THE HOISTWAY MUST BE IN ACCORDANCE WITH "SAFETY CODE FOR ELEVATORS AND ESCALATORS" (ASME A17.1) AND ALL STATE AND LOCAL CODES.
ELEVATOR HOISTWAY- DUE TO CLOSE RUNNING CLEARANCES OWNER/AGENT MUST ENSURE THAT HOISTWAY AND PIT (WHERE PROVIDED) ARE LEVEL, PLUMB AND SQUARE AND ARE IN ACCORDANCE WITH THE DIMENSIONS ON THESE DRAWINGS.
MINIMUM OVERHEAD CLEARANCE- OWNER/AGENT MUST ENSURE MINIMUM OVERHEAD CLEARANCE IS IN COMPLIANCE WITH CODES.
CONSTRUCTION SITE- OWNER/AGENT TO PROVIDE ALL MASONRY, CARPENTRY AND DRYWALL WORK AS REQUIRED AND SHALL PATCH AND MAKE GOOD (INCLUDING FINISH PAINTING) ALL AREAS WHERE WALLS/FLOORS MAY REQUIRE TO BE CUT, DRILLED OR ALTERED IN ANY WAY TO PERMIT THE PROPER INSTALLATION OF THE LIFT.
DIMENSIONS- CONTRACTOR/CUSTOMER TO VERIFY ALL DIMENSIONS AND REPORT ANY DISCREPANCIES TO OUR OFFICE IMMEDIATELY.

*STRUCTURAL
FLOOR/SUPPORT WALL LOADS- STRUCTURE TO ANCHOR A CRANK SHAFT AND SAFETY HARNESS, WHERE APPLICABLE/NEEDED, TO BE PROVIDED BY CONTRACTOR. CONTRACTOR TO ASSURE THAT BUILDING AND SHAFT WILL SAFELY SUPPORT ALL LOADS IMPOSED BY THE LIFT EQUIPMENT. REFER TO THE TABLES ON THIS DRAWING FOR LOADS IMPOSED BY THE EQUIPMENT.

*MACHINE ROOM (WHERE REQUIRED)
LOCATION / ACCESS- MACHINE ROOM LOCATED AT THE LOWEST LEVEL ADJACENT TO HOISTWAY, UNLESS SHOWN OTHERWISE ON THE LAYOUT DRAWINGS. FIELD ADJUSTMENT BY INSTALLER MAY BE NECESSARY TO MEET JOB SITE CONDITIONS OR REGULATIONS. MACHINE ROOM DOOR IS TO BE LOCKABLE AND IS TO MEET THE REQUIREMENTS OF THE AUTHORITY HAVING JURISDICTION.
SLEEVES FOR ELECTRIC LINES- FROM MACHINE ROOM TO HOISTWAY AS REQUIRED. (POSITION PER INSTALLERS INSTRUCTIONS).

TABLE 3

	DISCONNECT SIZE	FUSE SIZE	TIME DELAY	VOLTS	PHASE	FLA
MOTOR & EQUIP	30 AMPS	30 AMPS	208	208 VOLT	Three Phase	28.9 AMPS
MOTOR & EQUIP	60 AMPS	40 AMPS	230	230 VOLT	Single Phase	35.0 AMPS
CAB LIGHTS	15 AMPS	15 AMPS	115	115 V	Single Phase	

*ELECTRICAL
POWER SUPPLY- (SEE SPECIFICATIONS) LOCKABLE FUSED DISCONNECT WITH AUXILIARY CONTACT TO BRAKE THE BATTERY FEED, OR CIRCUIT BREAKERS WITH A 3-POLE BREAKER FOR BATTERY FEED REQUIRED, IN COMPLIANCE WITH ELECTRICAL CODE, AS FOLLOWS (LOCATED ON WALL ON LOCK JAMB SIDE OF MACHINE ROOM DOOR)
PERMANENT POWER- BEFORE INSTALLATION CAN BEGIN, PERMANENT POWER MUST BE SUPPLIED.

LIGHTING- THE ILLUMINATION SHALL BE NOT LESS THAN 200 LX (19 FC) AT THE FLOOR LEVEL IN ALL MACHINE ROOMS AND MACHINERY SPACES. ENSURE AT LEAST 100 LX (10 FC) AMBIENT LIGHTING OVER LIFT AREA.

PHONE- NEED A DEDICATED PHONE LAND LINE (NOT VOIP) FOR THE PHONE, WHERE APPLICABLE. FOR VOIP PLEASE CONTACT SAVARIA.

*ENTRANCES
FASCIA PANEL BELOW UPPER LEVEL ENTRANCE- WHERE REQUIRED, FASCIA PANEL MUST BE FASTENED TO A SOLID WALL AND BE PERPENDICULAR TO THE FLOOR AND WALLS. HOISTWAY FASCIA IS NOT SELF-SUPPORTING FOR LONG, CONTINUOUS RUNS VOID OF ENTRANCES. ADEQUATE SUPPORT FOR THE FASCIA MUST BE PROVIDED.

ENTRANCE ASSEMBLIES- ENTRANCE ASSEMBLIES MUST BE ADJUSTED TO ALIGN WITH PLATFORM AND INTERLOCK EQUIPMENT. OTHERS TO ALLOW AN ADEQUATE ROUGH OPENING.

RETURN WALLS- RETURN WALLS AT ENTRANCES MUST BE BUILT-IN BY OTHERS AFTER ENTRANCE ASSEMBLIES ARE IN PLACE. ENTRANCE ASSEMBLY MUST BE SECURELY FASTENED TO WALLS BY ELEVATOR CONTRACTOR.

NOTE:
DIMENSIONS SHOWN ON DRAWING ARE FOR REFERENCE ONLY.
MAXIMUM SPACE BETWEEN RAIL BRACKETS NOT TO EXCEED 48"

NOTE 1:
REFER TO MANUAL BEFORE ADJUSTING THIS SETTING

NOTE REFUGE SPACE PROVIDED BY PIT PROP 1067 mm (42") IN ACCORDANCE WITH CLAUSE 52.1.4.2.

NOTE LIFTING BEAM:
A 4000LB MIN SWL BEAM MUST BE PROVIDED IN THE OVERHEAD. BEAM TO BE POSITIONED AS SHOWN IN ELEVATION & PLAN VIEWS. FOR OVERHEAD OF 108" POSITION THE UNDERSIDE OF BEAM AT 104" & BEAM MUST BE TEMPORARY.

TABLE 4

MAX. SPEED (ft/min)	PIT / OVERHEAD REQUIREMENTS		
	PIT	TOTAL TRAVEL	MIN OVERHEAD
30	14" ***		NEW BLDG: 134"(3404) EXISTING BLDG: 108"(2743)

*** NOTE: Additional pit equipment required when over 36" deep, consult your local dealer for details

WARNING:
FORCES ONLY APPLICABLE FOR SEISMIC ZONES 0 AND 1. FOR SEISMIC ZONES OTHER THAN 0 OR 1 PLEASE CONSULT WITH MANUFACTURER FOR REGIONAL SPECIFIC REQUIREMENTS.

REV-000