

SECTIONAL VIEW - PROLIFT HD Model TYPE 3-36" OPENING

RAIL BRACKET

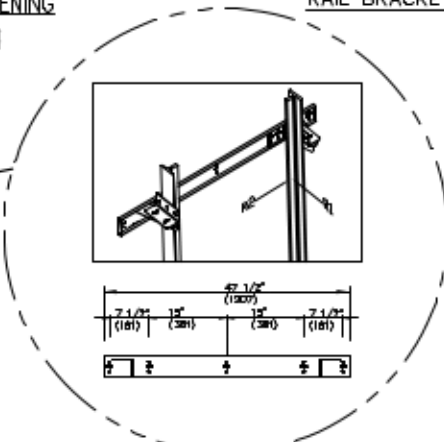
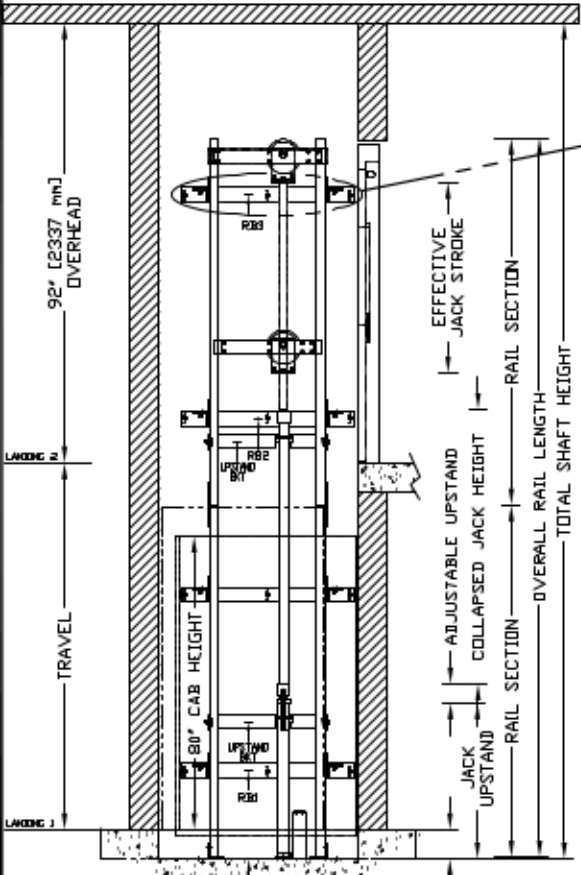

TOP RAIL BRACKET RB3	AT TOP OF HOISTWAY CONSULT YOUR CONCORD REPRESENTATIVE FOR EXACT LOCATION
INTERMEDIATE RAIL BRACKET RB2	48" [1219mm] INTERVALS ABOVE BOTTOM BRACKET
BOTTOM RAIL BRACKET RB1	24" [610mm] ABOVE PIT FLOOR

RAIL FORCES

*R1	*R2	CAPACITY
35503lbf.	251.50lbf.	1400 lbs.
304 lbf.	194 lbf.	1000 lbs.
RAIL WEIGHT : 80 lbs / ft		

R3 NOTE:

PIT FLOOR TO SUPPORT LOAD OF:
* (INCLUDES IMPACT)

CAPACITY	
6.4 Kips	1400 lbs.
5.33Kips	1000 lbs.

FOR TOTAL PULL-OUT FORCE ON RAIL BRACKET, R1 MUST BE DOUBLED eg 608 lbf for 1000 lbs.

PLAN VIEW - PROLIFT HD Model TYPE 3-36" OPENING

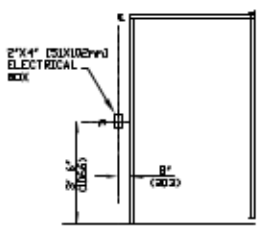
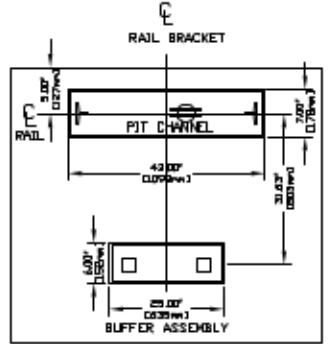
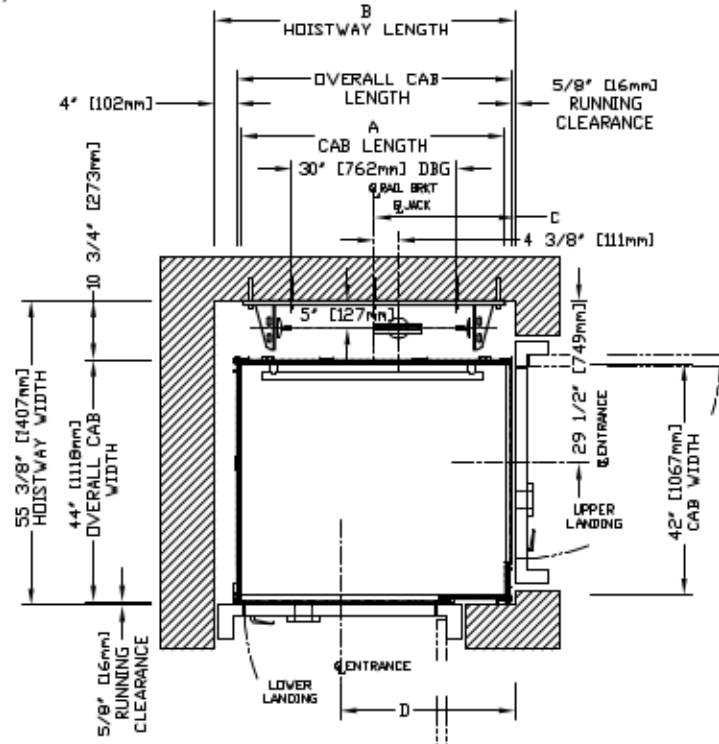

HALL FIXTURE LOCATION
LEFT HAND AS SHOWN
RIGHT HAND OPPOSITE
I. HALL BUTTON AT ALL FLOORS



HOISTWAY DIMENSION

A CAP LENGTH		B HOISTWAY LENGTH		C RAIL BRKT CENTER LINE		D ENTRANCE CENTER LINE	
mm	Inches	mm	Inches	mm	Inches	mm	Inches
1372	54	1540	60 5/8	727	28 5/8	962	37 7/8
1524	60	1692	66 5/8	803	31 5/8	1114	43 7/8

COMMERCIAL WHEELCHAIR LIFT
PROLIFT HD MODEL TYPE 3-36" OPENING

CUSTOMER:	DATE:	
PROJECT:	ROOM NO.:	
LOCATION:	COMPANY BY:	
	JOB No.:	DRAWING No.: