

SECTIONAL VIEW - PROLIFT HD Model TYPE 4-42" OPENING

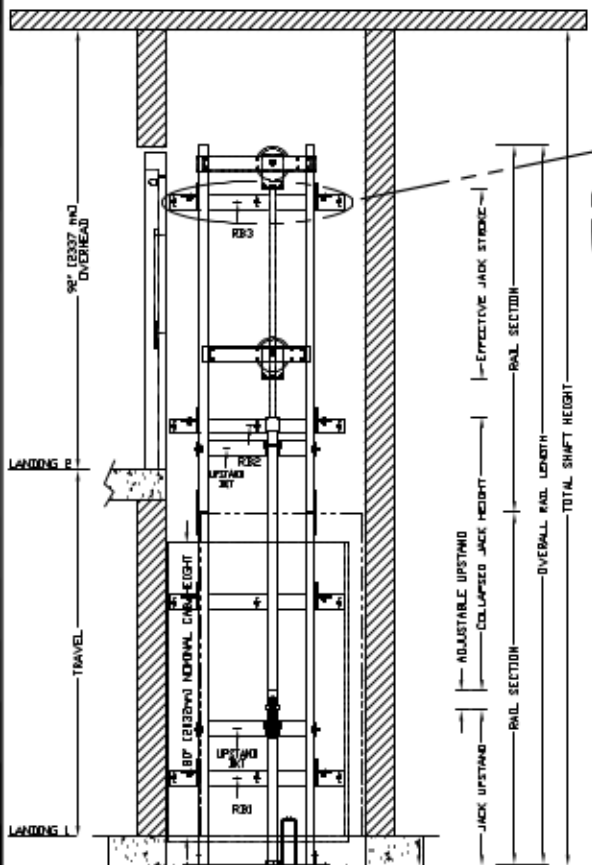

RAIL BRACKET

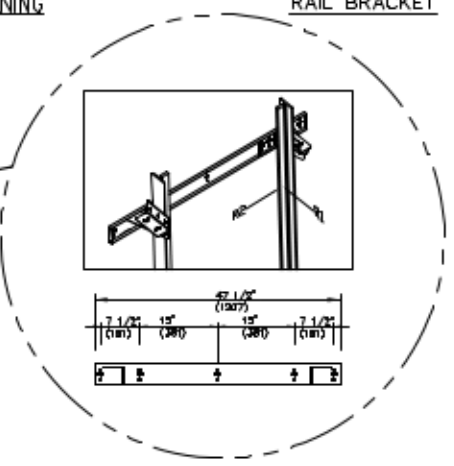

TOP RAIL BRACKET RB3	AT TOP OF HOISTWAY CONSULT YOUR CONCORD REPRESENTATIVE FOR EXACT LOCATION
INTERMEDIATE RAIL BRACKET RB2	48\" [1219mm] INTERVALS ABOVE BOTTOM BRACKET
BOTTOM RAIL BRACKET RB1	24\" [610mm] ABOVE PIT FLOOR



RAIL FORCES

*R1	*R2	CAPACITY
355.03lb.f.	251.50lb.f.	1400 lbs.
304 lb.f.	194 lb.f.	1000 lbs.
RAIL WEIGHT : 8.0 lbs / ft		

R3 NOTE:
PIT FLOOR TO SUPPORT LOAD OF:
* (INCLUDES IMPACT)

CAPACITY	
6.4 Kips	1400 lbs.
5.33Kips	1000 lbs.

FOR TOTAL PULL-OUT FORCE ON RAIL BRACKET, R1 MUST BE DOUBLED eg 608 lb.f for 1000 lbs.

PLAN VIEW - PROLIFT HD Model TYPE 4-42" OPENING

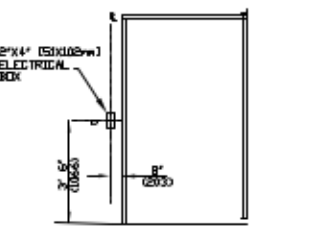
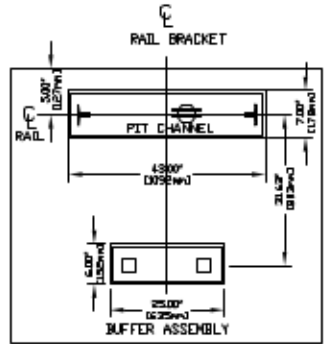
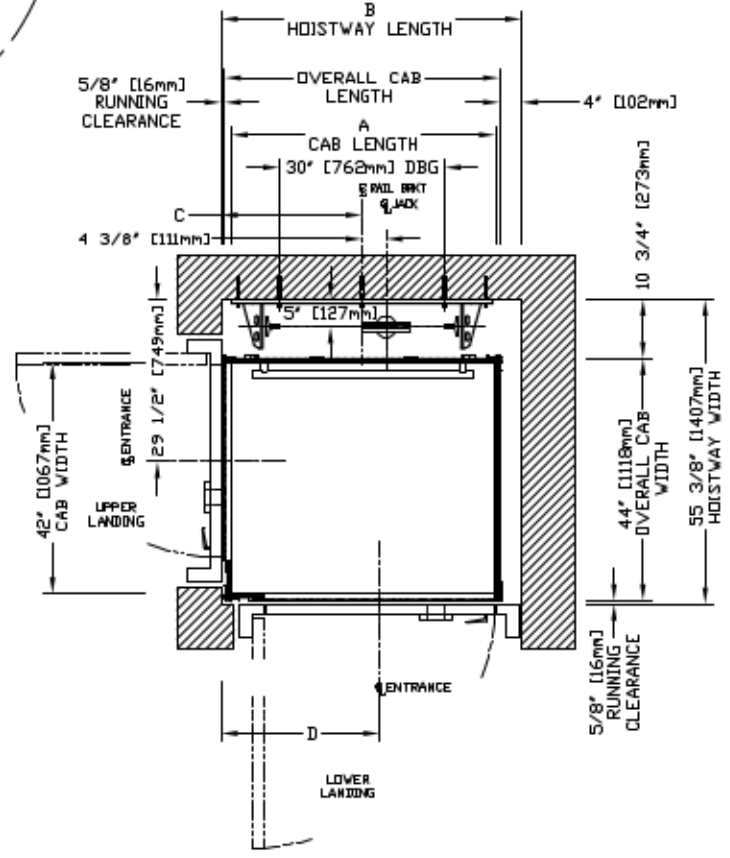

HALL FIXTURE LOCATION
LEFT HAND AS SHOWN
RIGHT HAND OPPOSITE
I. HALL BUTTON AT ALL FLOORS

HOISTWAY DIMENSION

A CAP LENGTH		B HOISTWAY LENGTH		C RAIL BRKT CENTER LINE		D ENTRANCE CENTER LINE	
mm	Inches	mm	Inches	mm	Inches	mm	Inches
1372	54	1540	60 5/8	727	28 5/8	886	34 7/8
1524	60	1692	66 5/8	803	31 5/8	1038	40 7/8

COMMERCIAL WHEELCHAIR LIFT
PROLIFT HD MODEL TYPE 4-42" OPENING

CUSTOMER:	DATE:	
PROJECT:	ROOM NO.:	
LOCATION:	COMPANY BY: JOB No. PROJECT No.	