

**SOLATUBE 750 DS-O
(21 IN/530 MM)
CURB CAP OPEN CEILING**

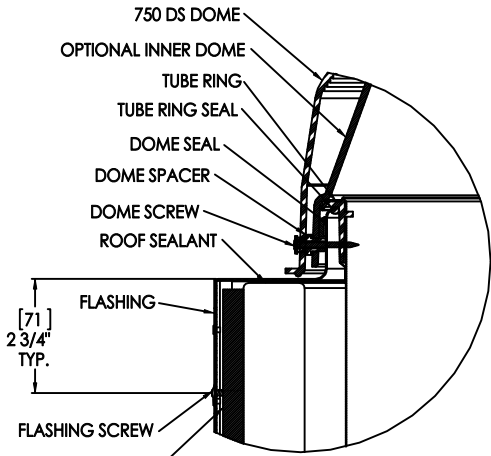

**DETAIL B
SCALE 3 : 1**

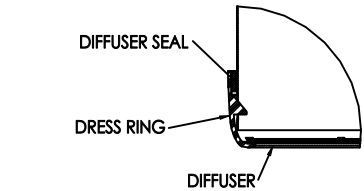

**DETAIL C
SCALE 3 : 1**

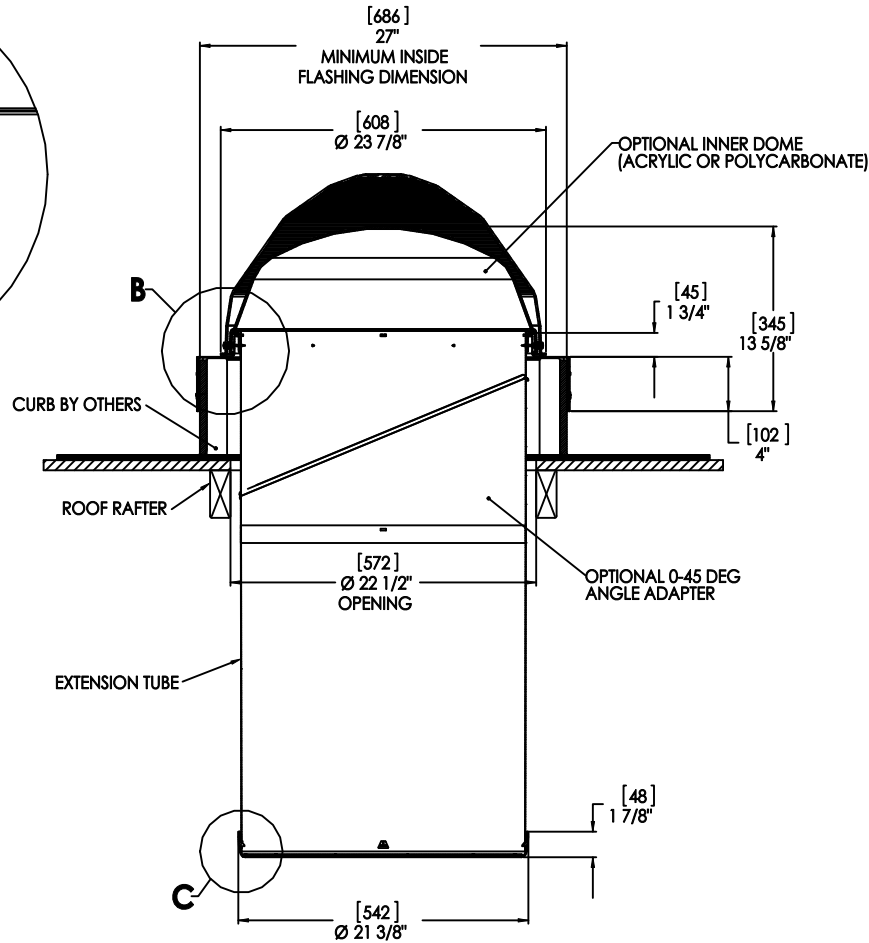

**FULL SECTION
SCALE 1:1**

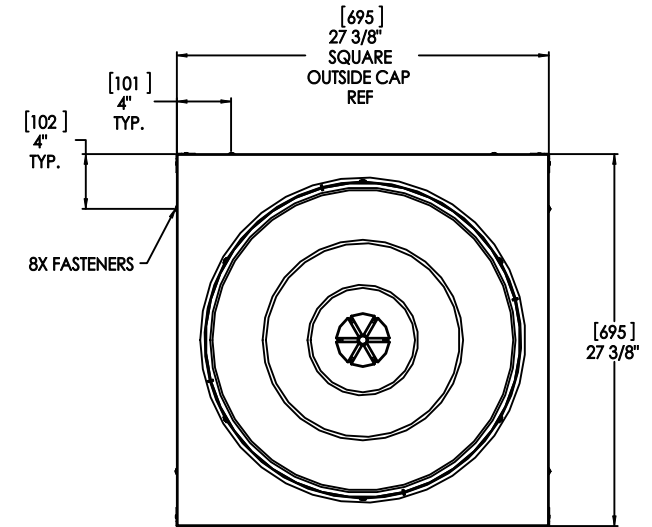

**TOP VIEW
SCALE 1:1**

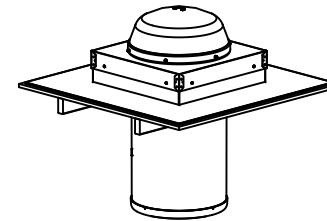

NOTES:

1. STRUCTURAL ELEMENTS (PLYWOOD, RAFTERS, DRYWALL ETC.) BY OTHERS & SHOWN FOR REFERENCE ONLY.
2. ALL TUBE JOINTS & SEAMS TAPED WITH 2" FOIL TAPE (NOT SHOWN).
3. DIMENSIONS IN BRACKETS ARE METRIC UNLESS OTHERWISE SPECIFIED.
4. 6" MIN CLEARANCE SHOULD BE MAINTAINED FROM ALL SOLATUBE COMPONENTS AND OTHER PLENUM COMPONENTS.

UNLESS OTHERWISE SPECIFIED:		SOLATUBE INTERNATIONAL, INC. COPYRIGHT 2013 WWW.SOLATUBE.COM		 2750 GARA ROAD, WYVA 14274 CALIFORNIA, 90411-0041 PH (714) 501-4400	
DIMENSION TOLERANCE SPECIFIED:		FRACTIONS ± 1/16"		TITLE: 750 DS-O (21") CURB CAP OPEN CEILING	
INCH ± .015		MILLIMETER ± .25		SIZE	
DIA ± .015		[C] ± 1.5		DWG. NO. WEB-750-CF-OC	
MATERIAL	DRAWN BY	DATE	CHECKED BY	DATE	REV 2
-	STEVENS	3/2/09	-	-	
FINISH	CHECKED BY	DATE	APPROVED BY	DATE	
-	-	-	-	-	
DO NOT SCALE DRAWING				SCALE: 1:1	SHEET 1 OF 1