

4

3

2

1

REVISIONS			
REV.	DESCRIPTION	DATE	BY
01	ADJUSTED FOR CLARITY	11/11/2022	JC
02	REVISED TO MEET STANDARD	12/29/2022	JC

**POST WITH PLATE SIZES:**

- 2 1/2" SQ.
- 3 1/4" SQ.
- 4" SQ.

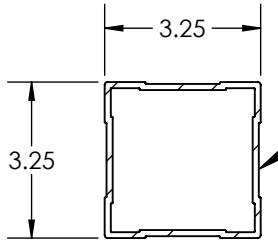

**SECTION D  
SCALE 1 : 4**

B

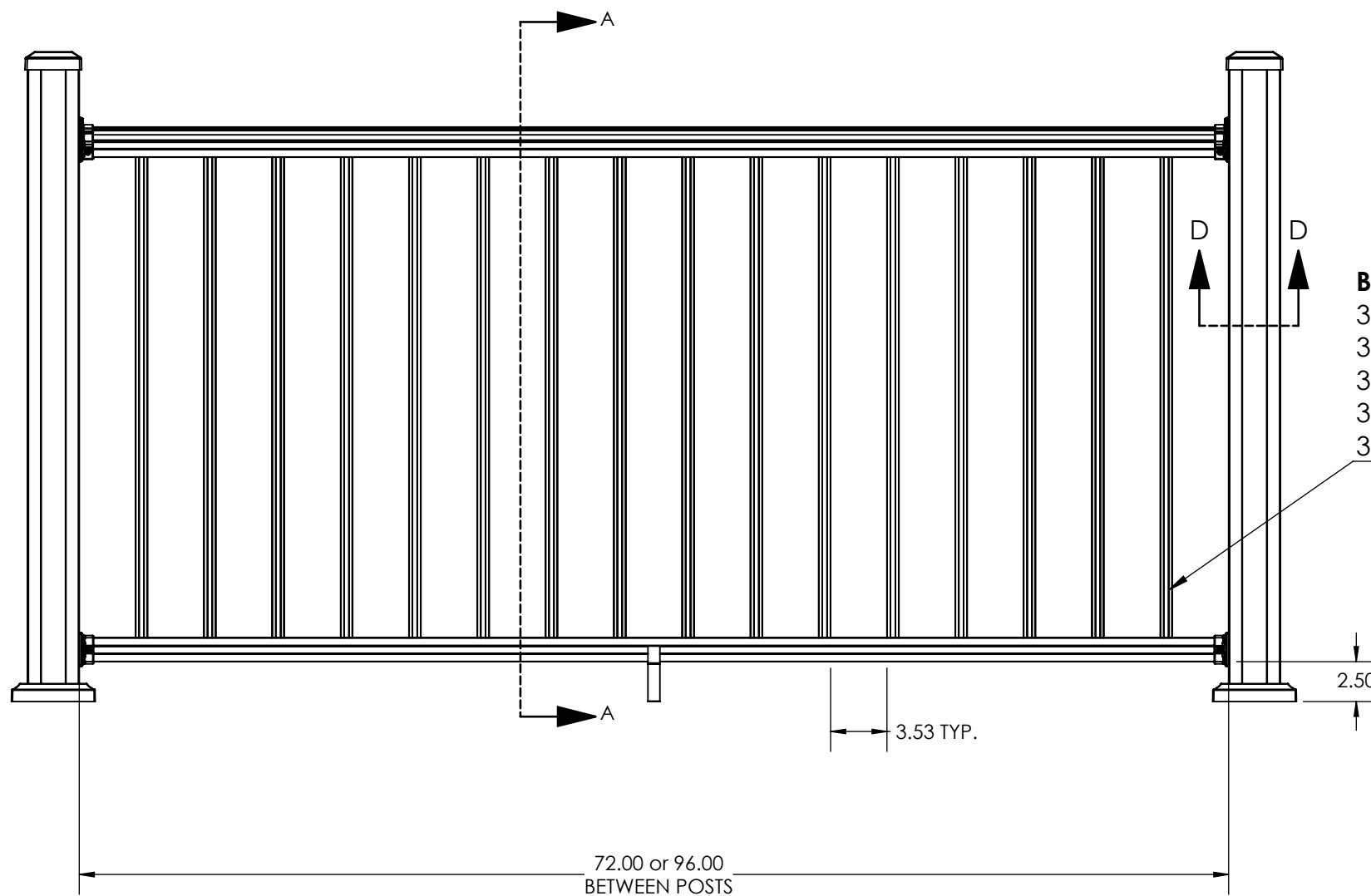

**BALUSTER OPTIONS:**

- 3/4" SQUARE
- 3/4" ROUND
- 3/4" SQ TWISTED
- 3/4" SQ HAMMERED
- 3/4" SQ BOWED

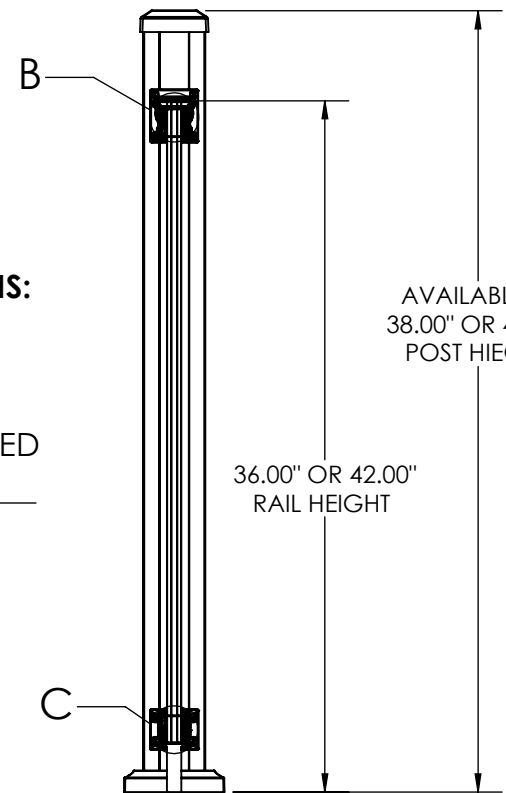

**SECTION A-A  
SCALE 1 : 10**

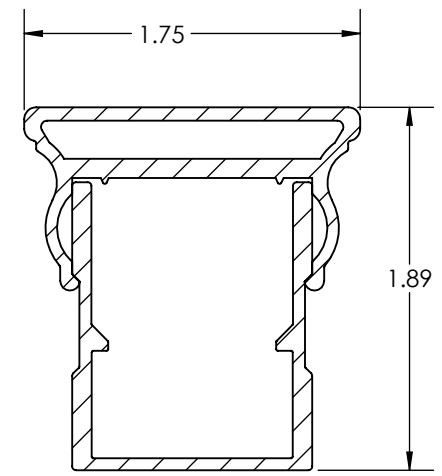

**DETAIL B  
SCALE 1 : 1**

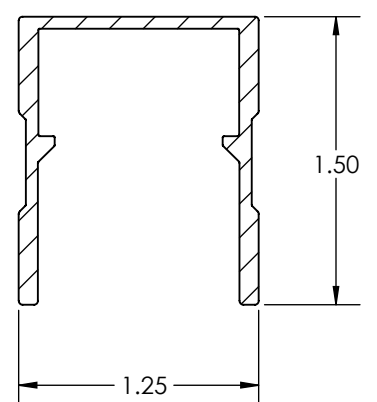

**DETAIL C  
SCALE 1 : 1**

A

A

EBMS #:		NAME	DATE	Key-Link Fencing and Railing 110 Peters Road, New Holland, Pa 17557
LAST SAVE DATE	MODELED BY	E.Hunt	8/20/2020	
3/1/2023	DRAWN BY	E.Hunt	8/20/2020	
PROPRIETARY AND CONFIDENTIAL	APPROVED BY	D.Kinsey	10/06/2020	TITLE:
THE INFORMATION CONTAINED IN THIS DRAWING IS THE PROPERTY OF SUPERIOR PLASTIC PRODUCTS. ANY REPRODUCTION IN PART OR IN WHOLE WITHOUT THE WRITTEN PERMISSION OF SUPERIOR PLASTIC PRODUCTS IS PROHIBITED.	PROJECTION	UNLESS OTHERWISE SPECIFIED: 1. DIMENSIONS ARE IN INCHES 2. BREAK ALL SHARP EDGES 3. TOLERANCES: FRACTIONAL ± 1/64" ANGULAR:MACH ±1.0° BEND ±1.0° TWO PLACE DECIMAL ±0.01" THREE PLACE DECIMAL ±0.005"		AMERICAN SERIES, 36'/42' HT. X 6'/8' W. LEVEL RAILING SECTION
	DO NOT SCALE DRAWING			
	FINISH	N/A	MATERIAL	
	SIZE	DWG. NO.	REV	
	<b>B</b>	<b>110547</b>	02	
	SCALE: 1:16	WEIGHT: 15.14	SHEET 1 OF 1	

4

3

2

1