

NOTE:
 1/16" TOLERANCE
 ALLOWED FROM CENTERLINE
 FOR EMBOSSEMENT LOCATIONS
 TOP TO BOTTOM
 AND SIDE TO SIDE.

NOTE:
 THIS LAYOUT BASED ON:
 3'0" X 6'8" EMBOSSED DOOR
 FOR 7'0 DOORS
 EMBOSSEMENT LOCATION
 DIFFERENCE IS SPLIT BETWEEN
 TOP AND BOTTOM RAILS

EMBOSSEMENT PROFILE
SECTION A-A
 SCALE 16X

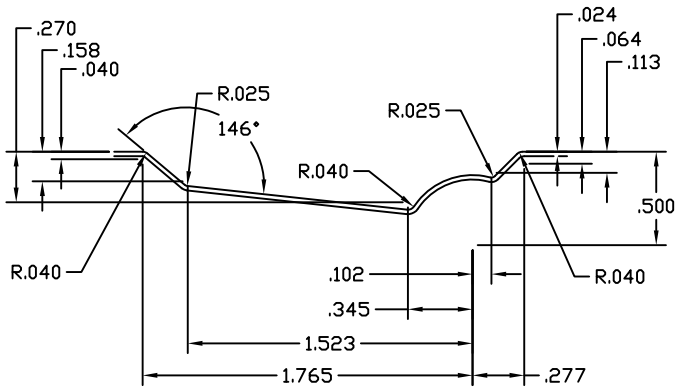

EMBOSSEMENT
SECTION B-B

SCALE 2X
 ALL DIMENSIONS (T.S.C.) TO SHARP CORNER

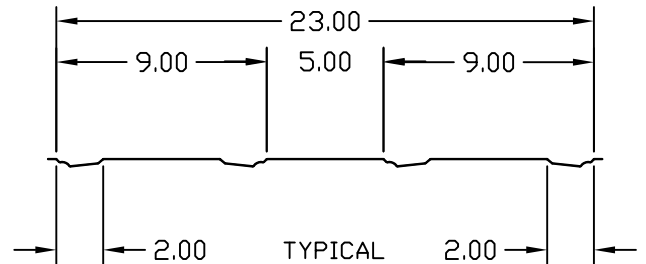

TRUE 4 PANEL
 EMBOSSEMENT OPTION
 FOR STEEL DOORS

DWG#	II-11
DATE	2-15-5
NAME	MJP
SECTION	II
PAGE	11