

ATTACH HEADER MEMBERS TOGETHER W/ (2) #10-16 SCREWS @ 12" O.C.

ATTACH JAMBS STUDS TOGETHER W/ (2) #10-16 SCREWS @ 12" O.C.

ATTACH TRACK TO JAMB STUDS W/ (6) #10-16 SCREWS

PIECE OF TRACK (54 MIL) ATTACH TO HEADER W/ (3) #10-16 SCREWS @ EACH FLANGE

CLOSURE TRACK (54 MIL) AS REQUIRED FOR HEADER ATTACHMENT W/ (4) #10-16 SCREWS @ EACH LEG

FULL HEIGHT JAMB STUDS

STEEL STUD HEADER
(2) STUD MEMBERS
(2) TRACK MEMBERS

ALL HEADER MEMBERS MUST SPAN ENTIRE LENGTH OF OPENING W/O SPLICES

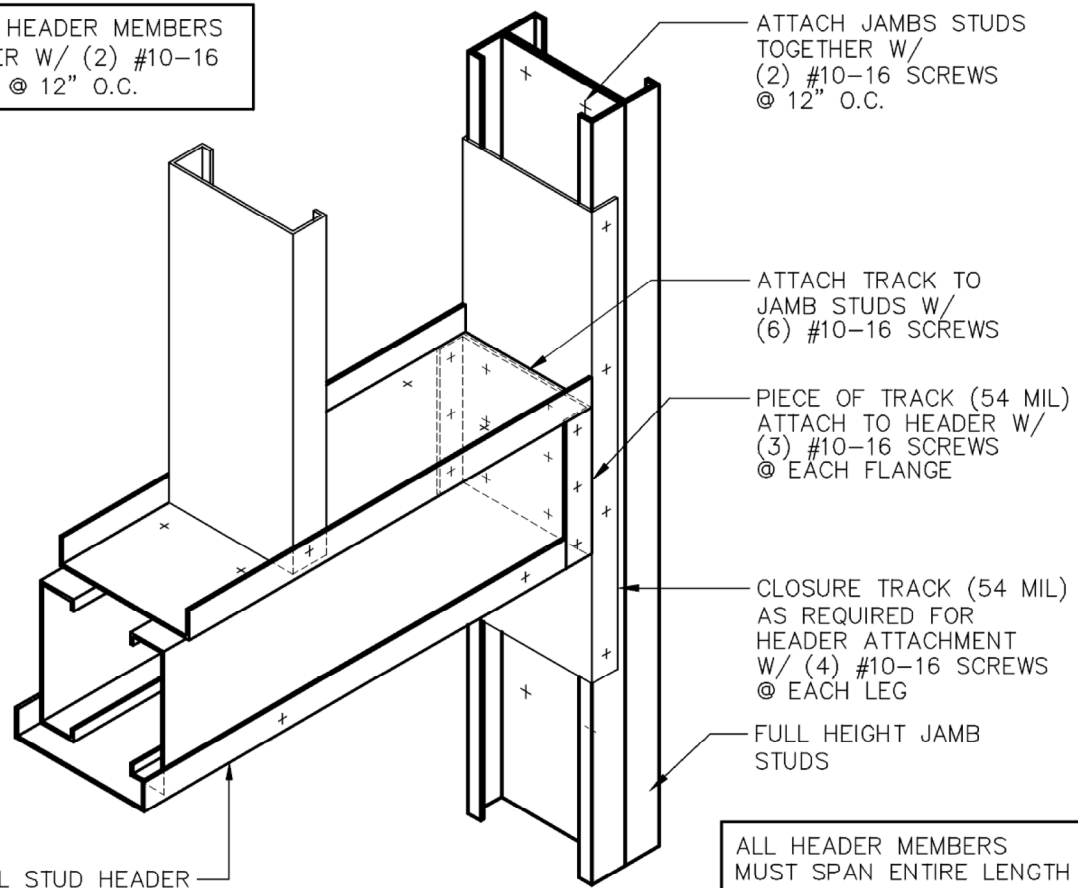

TELLING™



BUILDSTRONG

6272 CENTER STREET
MENTOR, OHIO 44060
PHONE: 440-974-3370

DETAIL IS FOR REFERENCE ONLY. NOT FOR CONSTRUCTION.

DETAIL PROVIDED BY:



100 CAMELOT DRIVE
FOND DU LAC, WI 54935
PHONE: (920) 926-9800

TYPICAL HEADER — JAMB DETAIL