

∠ 2" x 2" x 14 GA.
x 1/2" SHORTER THAN
STUD DEPTH (50 KSI)
W/ (4) #10-16 SCREWS
@ EACH LEG

STEEL STUD SILL:
(1) TRACK MEMBER

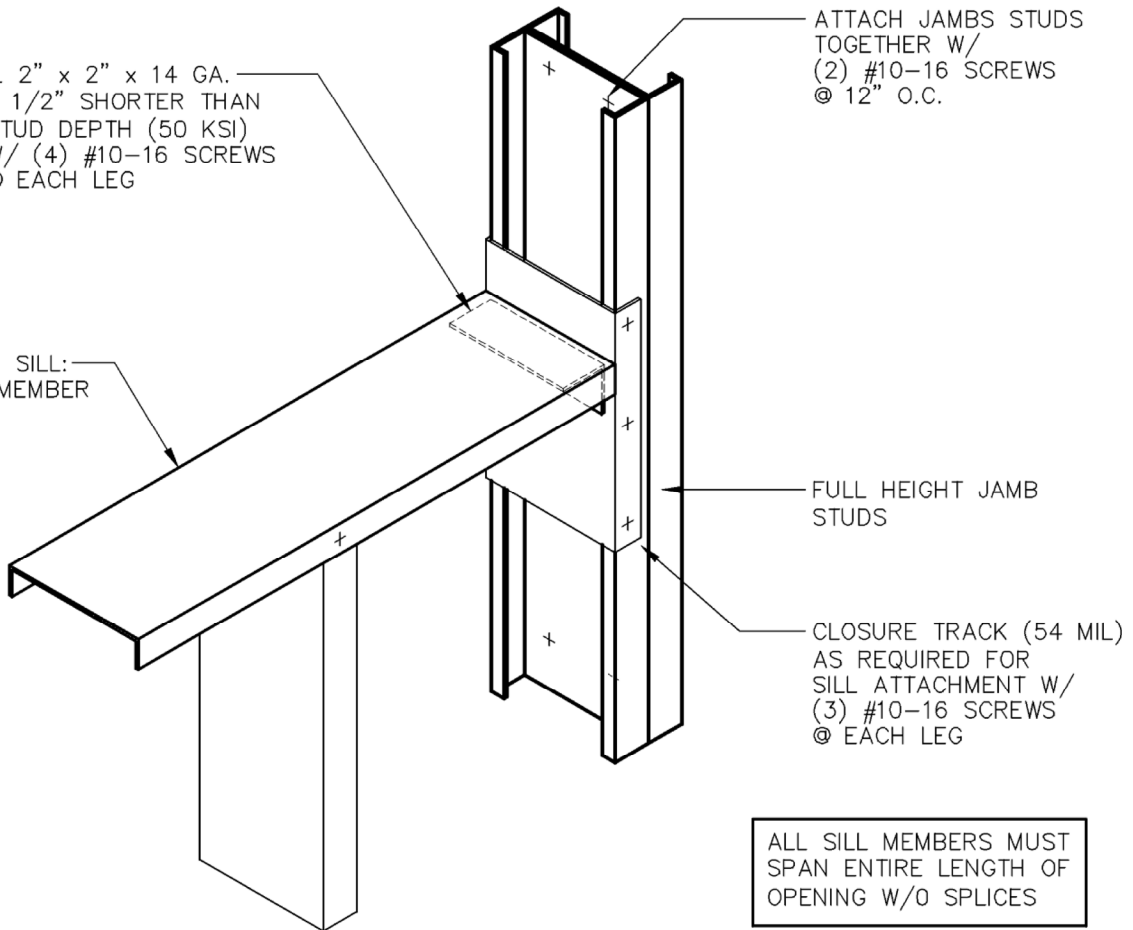

TELLING™

BUILDSTRONG
6272 CENTER STREET
MENTOR, OHIO 44060
PHONE: 440-974-3370

DETAIL IS FOR
REFERENCE ONLY.
NOT FOR CONSTRUCTION.

DETAIL PROVIDED BY:

**EXCEL
ENGINEERING**
100 CAMELOT DRIVE
FOND DU LAC, WI 54935
PHONE: (920) 926-9800

TYPICAL SILL — JAMB DETAIL