

@ JAMB CONDITIONS

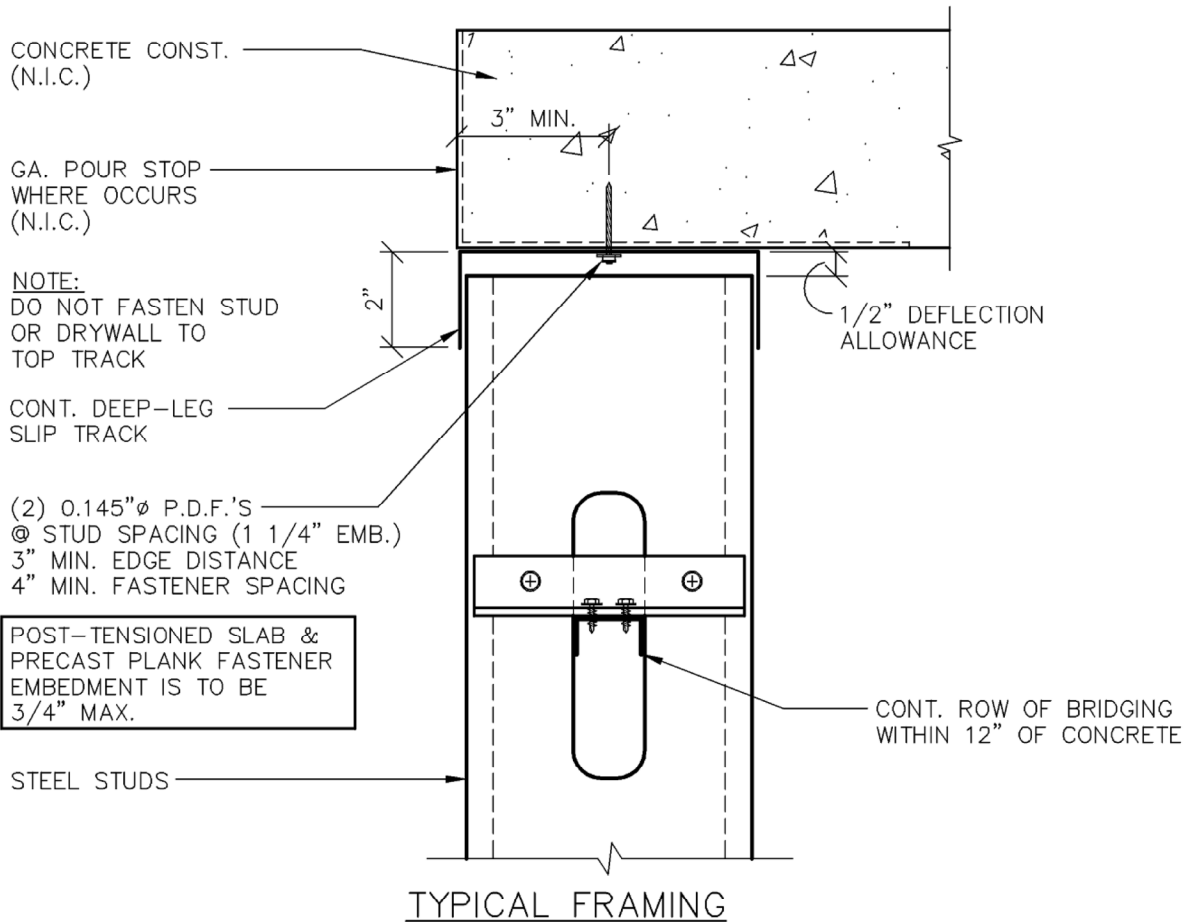

@ CONCRETE
SLIP TRACK ATTACHMENT

TELLING™
BUILDSTRONG
6272 CENTER STREET
MENTOR, OHIO 44060
PHONE: 440-974-3370

DETAIL IS FOR
REFERENCE ONLY.
NOT FOR CONSTRUCTION.

DETAIL PROVIDED BY:

EXCEL
ENGINEERING

100 CAMELOT DRIVE
FOND DU LAC, WI 54935
PHONE: (920) 926-9800