

				REVISION HISTORY	
REV.	DATE	BY	EFFCTV.	DESCRIPTION	

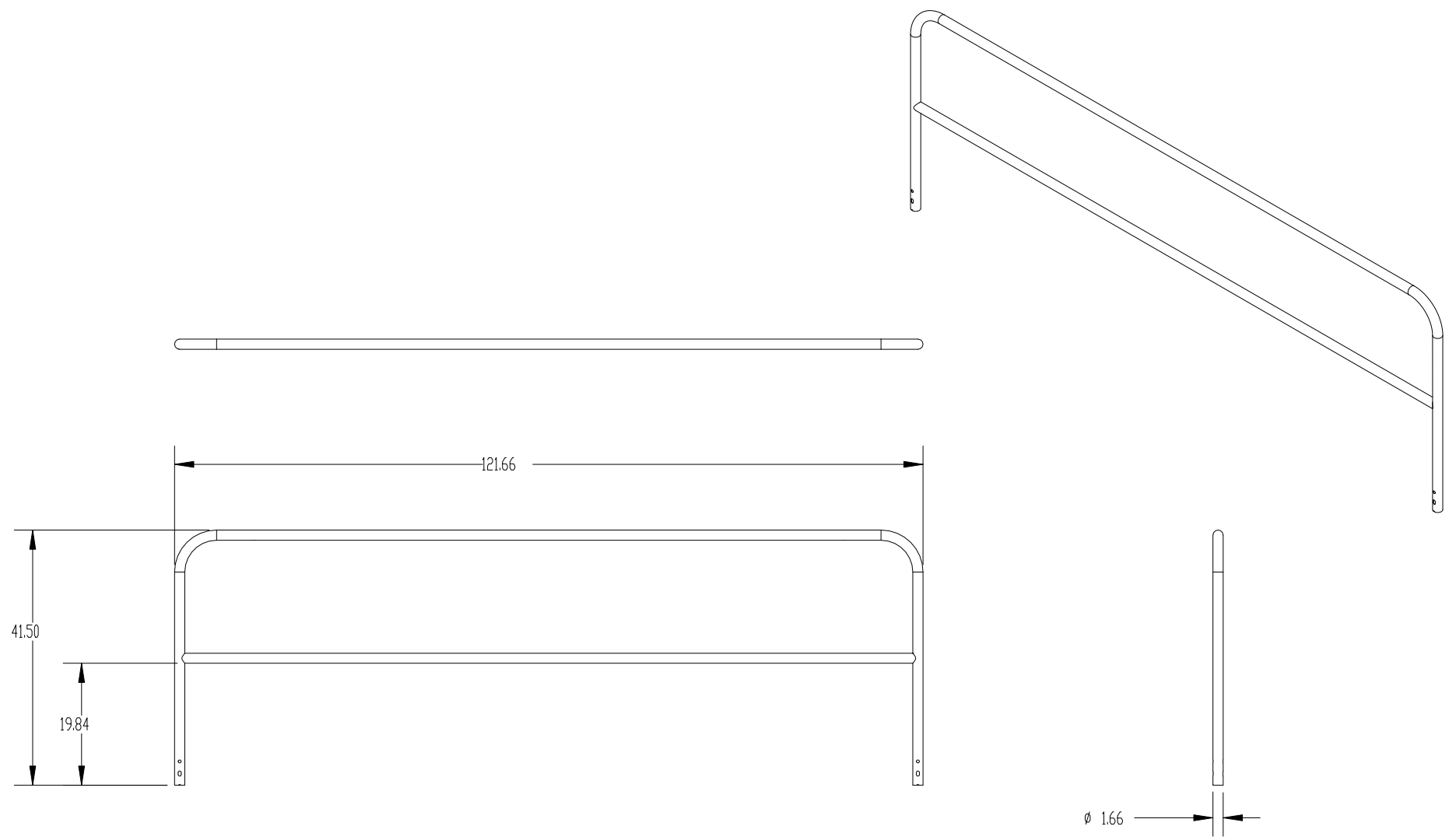

**NOTES:**

1. ALL DIMENSIONS ARE IN INCHES.
2. BOXED DIMENSIONS INDICATE OPERATOR Q.C. CHECK.
3. WELD TO BE FREE OF SPATTER & POROSITY w/GOOD PENETRATION.
4. PART TO BE FREE OF BURRS, SHARP EDGES & LASER SLAG.
5. PART TO SATISFY THE REQUIREMENTS, SPECIFIED AND IMPLIED.
6. FINISH - POWDER COAT YELLOW.

FINISH: POWDER COAT YELLOW		CONFIDENTIALITY NOTICE : THIS DRAWING AND ALL INFORMATION CONTAINED WITHIN IT ARE THE PROPERTY OF TIE DOWN ENGINEERING, ATLANTA, GA 30336. ALL RIGHT ARE RESERVED.			
DRAWN:	THIRD ANGLE PROJECTION	GENERAL TOLERANCES:	404-344-0000 • TIEDOWN.COM 605 STONEHILL DRIVE SW, ATLANTA, GA 30336		
CHECKED:	ALL UNITS ARE IN INCHES UNLESS OTHERWISE SPECIFIED	Decimal .XX +/- 0.1	PART NAME: ZIP GUARDRAIL - 10' RZ GUARDRAIL, HASLA STEEL, YELLOW		
APPROVED:	PART WEIGHT: LBS	Decimal .XXX +/- 0.06	MATERIAL: WELDMENT		
	SHEET SIZE: ANSI A	Angles +/- 1°	PART NUMBER: 70758-ARCAT	SCALE: 1:1	REV: 1 of 1
		Hole Ø +/- 0.008			