

REVISION HISTORY				DESCRIPTION
REV.	DATE	BY	EFFCTV.	

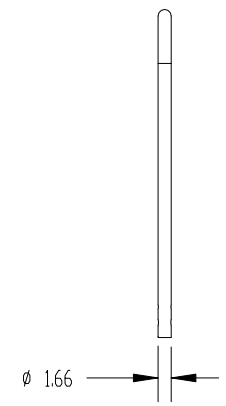
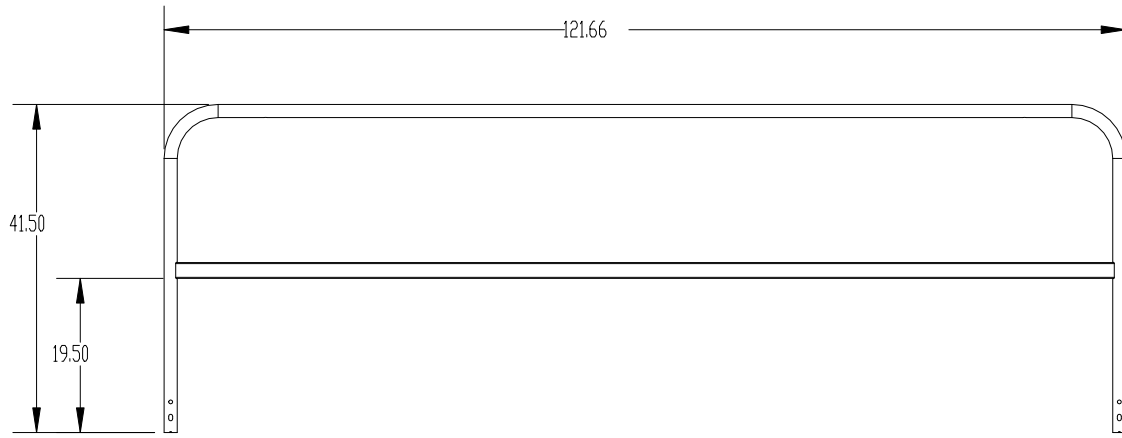
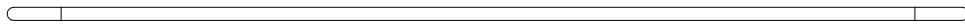
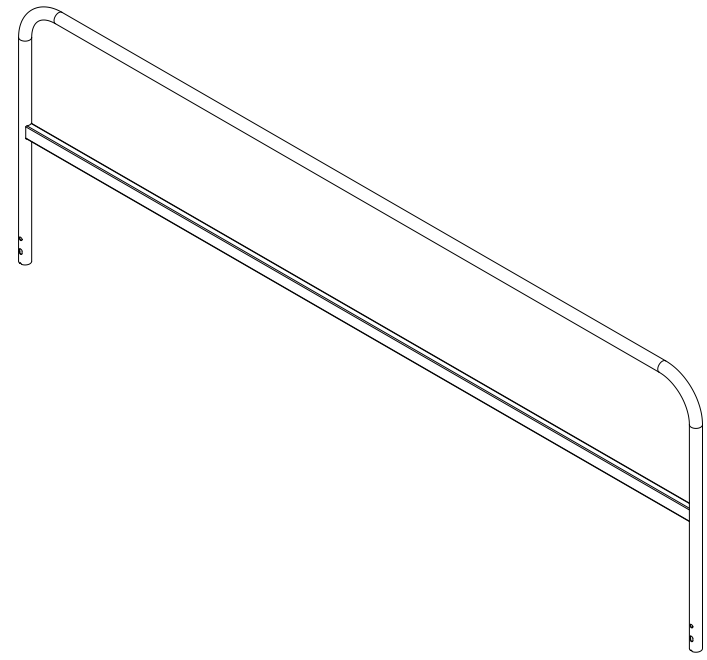

NOTES:

1. ALL DIMENSIONS ARE IN INCHES.
2. BOXED DIMENSIONS INDICATE OPERATOR Q.C. CHECK.
3. WELD TO BE FREE OF SPATTER & POROSITY w/GOOD PENETRATION.
4. PART TO BE FREE OF BURRS, SHARP EDGES & LASER SLAG.
5. PART TO SATISFY THE REQUIREMENTS, SPECIFIED AND IMPLIED.
6. FINISH - PRE-GAV.

FINISH: PRE-GAV		CONFIDENTIALITY NOTICE : THIS DRAWING AND ALL INFORMATION CONTAINED WITHIN IT ARE THE PROPERTY OF TIE DOWN ENGINEERING, ATLANTA, GA 30336. ALL RIGHT ARE RESERVED.		
DRAWN:	THIRD ANGLE PROJECTION	GENERAL TOLERANCES:	404-344-0000 • TIEDOWN.COM 605 STONEHILL DRIVE SW, ATLANTA, GA 30336	
CHECKED:	ALL UNITS ARE IN INCHES UNLESS OTHERWISE SPECIFIED	Decimal X.X +/- 0.1	PART NAME: ZIP GUARD RAIL - 10' RZ GUARDRAIL PRE-GALV	
APPROVED:	PART WEIGHT: LBS	Decimal XXX +/- 0.02	MATERIAL: WELDMENT	
	SHEET SIZE: ANSI A	Decimal XXXX +/- 0.010	PART NUMBER: 70764-ARCAT	
		Angles +/- 1°	SCALE: 1:1	REV: 1 of 1
		Hole ϕ +/- 0.008		