

				REVISION HISTORY	
REV.	DATE	BY	EFFCTV.	DESCRIPTION	

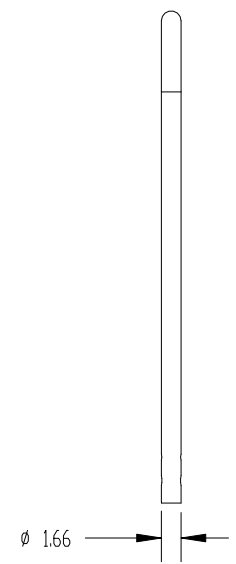
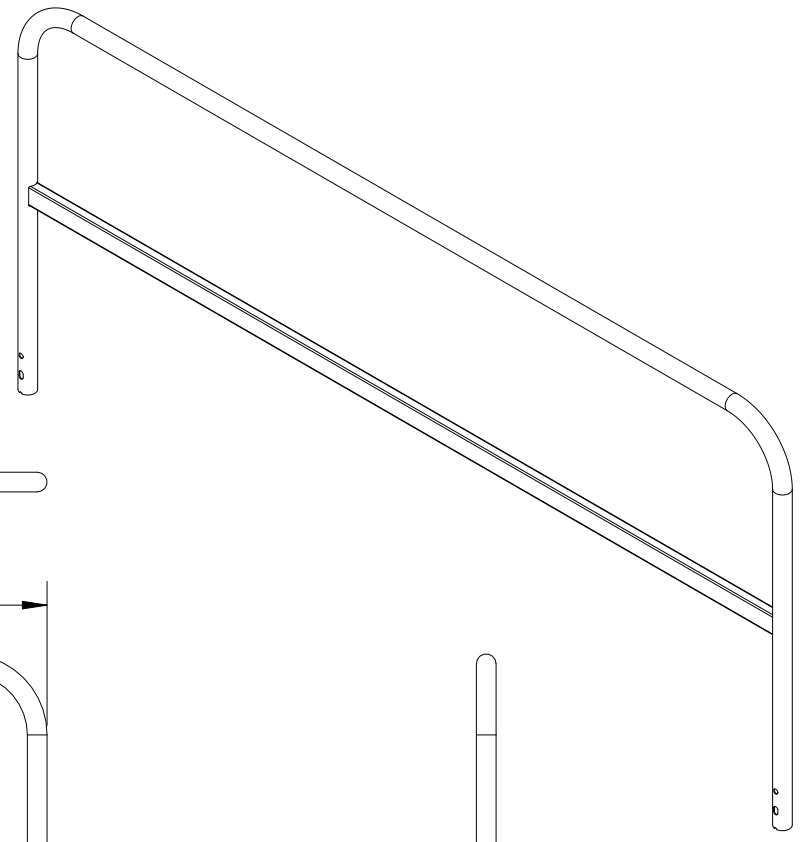

- NOTES:**
1. ALL DIMENSIONS ARE IN INCHES.
 2. BOXED DIMENSIONS INDICATE OPERATOR Q.C. CHECK.
 3. WELD TO BE FREE OF SPATTER & POROSITY w/GOOD PENETRATION.
 4. PART TO BE FREE OF BURRS, SHARP EDGES & LASER SLAG.
 5. PART TO SATISFY THE REQUIREMENTS, SPECIFIED AND IMPLIED.
 6. FINISH - PRE-GAV.

FINISH: PRE-GAV		CONFIDENTIALITY NOTICE : THIS DRAWING AND ALL INFORMATION CONTAINED WITHIN IT ARE THE PROPERTY OF TIE DOWN ENGINEERING, ATLANTA, GA 30336. ALL RIGHT ARE RESERVED.			
DRAWN:	THIRD ANGLE PROJECTION	GENERAL TOLERANCES:	404-344-0000 • TIEDOWN.COM 605 STONEHILL DRIVE SW, ATLANTA, GA 30336		
CHECKED:	ALL UNITS ARE IN INCHES UNLESS OTHERWISE SPECIFIED	Decimal .XX +/- 0.1	PART NAME: ZIP GUARDRAIL - 7-1/2' RZ GUARDRAIL PRE-GALV		
APPROVED:	PART WEIGHT: LBS	Decimal .XXX +/- 0.06	MATERIAL: WELDMENT		
	SHEET SIZE: ANSI A	Angles +/- 1°	PART NUMBER: 70765-ARCAT	SCALE: 1:1	REV: 1 of 1
		Hole Ø +/- 0.008			