

# IPE WOOD TILE LAYOUT

24" x 48" x 1-5/8"

National Distribution Tel: 213-550-3803  
Toll Free: 888-550-3803 Fax: 213-380-5561

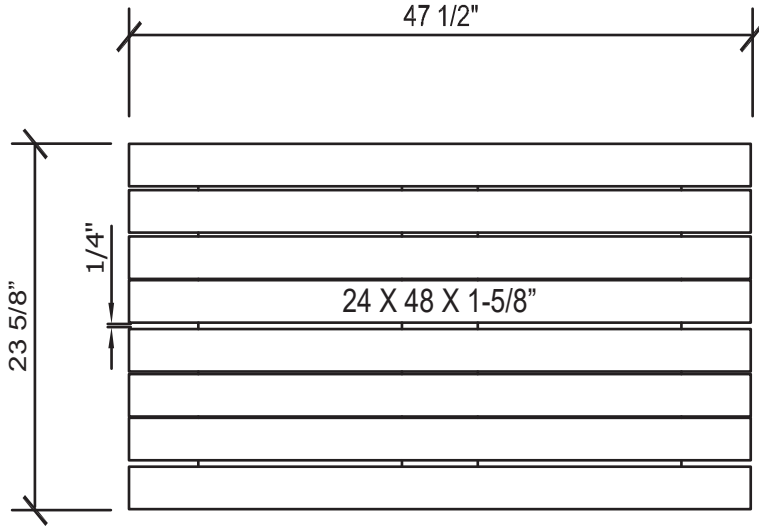

TOP VIEW

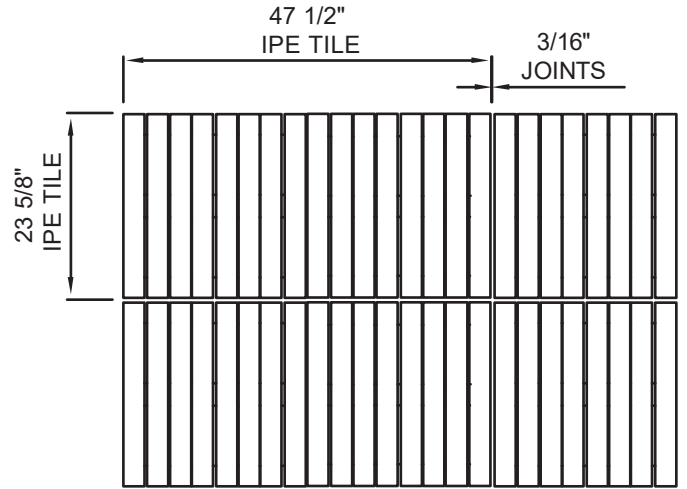

SQUARE LAYOUT

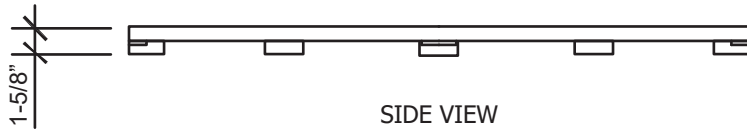

SIDE VIEW

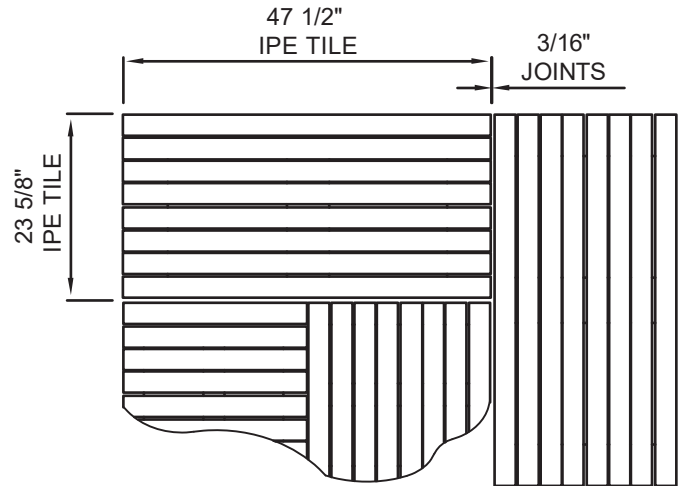

CROSS HATCH LAYOUT

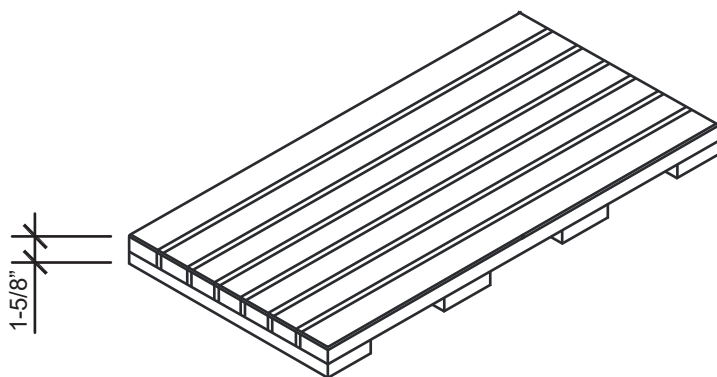

ISOMETRIC VIEW

**GENERAL NOTES: APPLY TO ALL OF THE ABOVE PRODUCTS**

1. INSTALLATION MUST BE COMPLETED IN ACCORDANCE WITH TILE TECH INC PRODUCT SPECIFICATIONS.
2. DRAWING NOT TO SCALE.
3. USE OF BUFFER PADS IS MANDATORY.
4. CONTRACTOR'S NOTE: FOR PRODUCT AND COMPANY INFORMATION VISIT [www.TILETECHPAVERS.com](http://www.TILETECHPAVERS.com)