

TORMAX 1201 SWING DOOR OPERATOR

DOUBLE EGRESS, VISIBLE R.H. INSWING, R.H. OUTSWING
 BUTT HUNG AND OFFSET PIVOT APPLICATION

JOB NAME: _____ DATE: _____
 DOOR LOCATION: _____ DOOR NO: _____ SHEET _____ OF _____

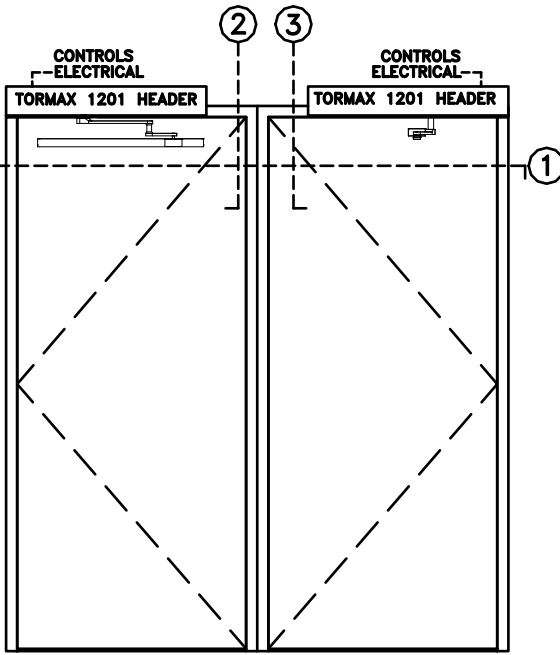

ELEVATION

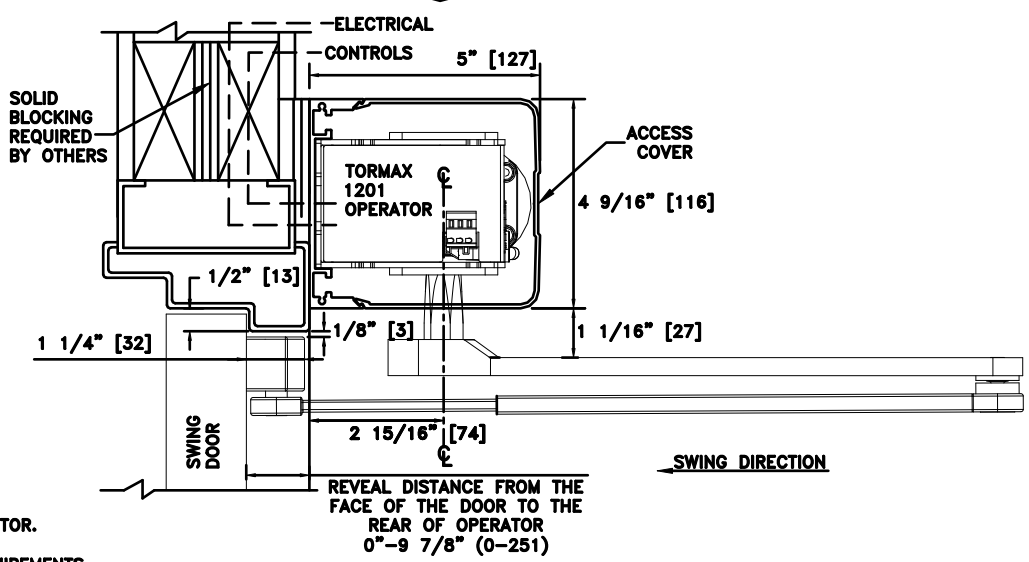
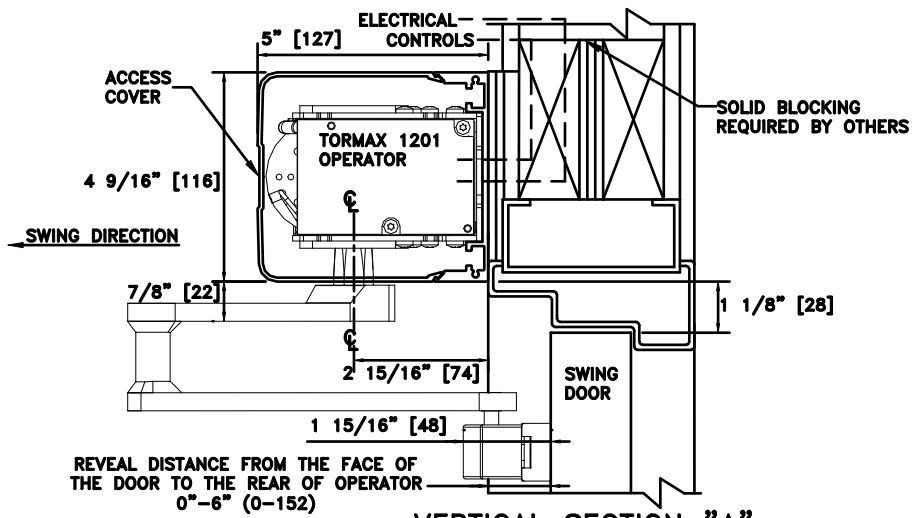
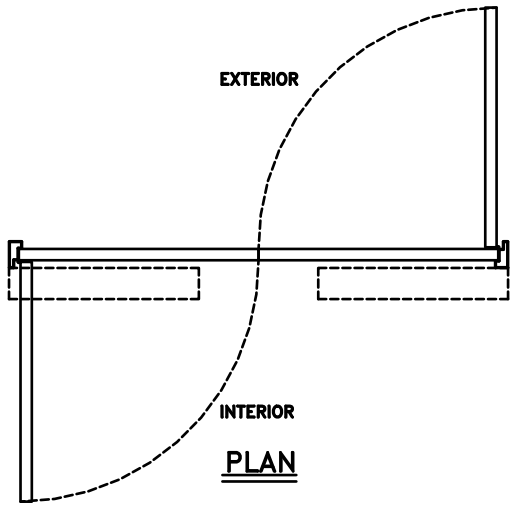
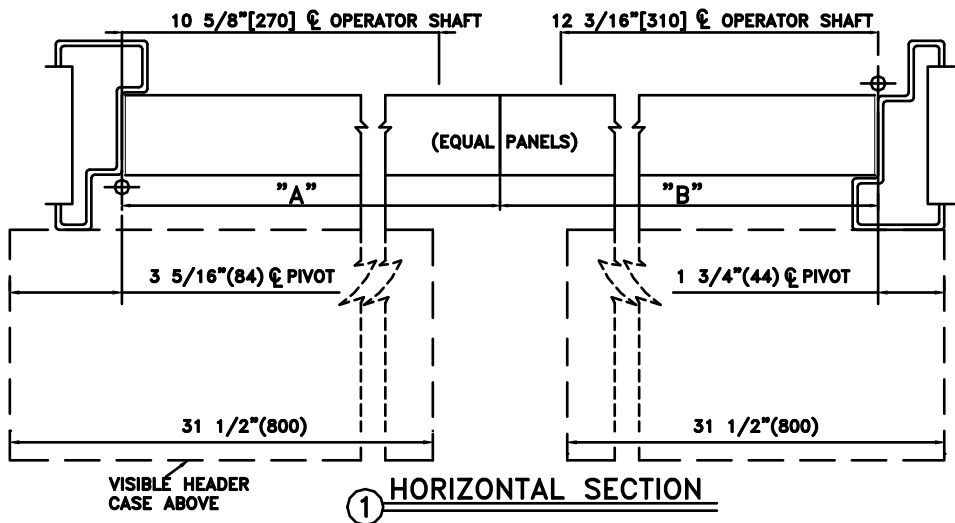

- NOTES:
 1. DETAILS NOT TO SCALE.
 2. ELECTRICAL REQUIREMENTS:
 120VAC, 5AMPS MIN. TO OPERATOR BY ELECTRICAL CONTRACTOR.
 3. DOORS, FRAMES AND HARDWARE BY OTHERS.
 4. 32" CLEAR DOOR OPENING REQUIRED TO MEET A.D.A. REQUIREMENTS.
 5. DOORS MUST BE NON-LATCHED FOR PROPER OPERATION.
 6. OPERATOR HEADER IS AVAILABLE FOR FULL WIDTH DOOR APPLICATIONS.
 7. OPERATOR CAN BE CONFIGURED TO MEET ANSI STANDARDS A156.10 & ANSI A156.19