

SINGLE DOOR, VISIBLE R.H. OUTSWING  
 BUTT HUNG, OR OFFSET PIVOT APPLICATION

JOB NAME: \_\_\_\_\_ DATE: \_\_\_\_\_  
 DOOR LOCATION: \_\_\_\_\_ DOOR NO: \_\_\_\_\_ SHEET \_\_\_\_\_ OF \_\_\_\_\_

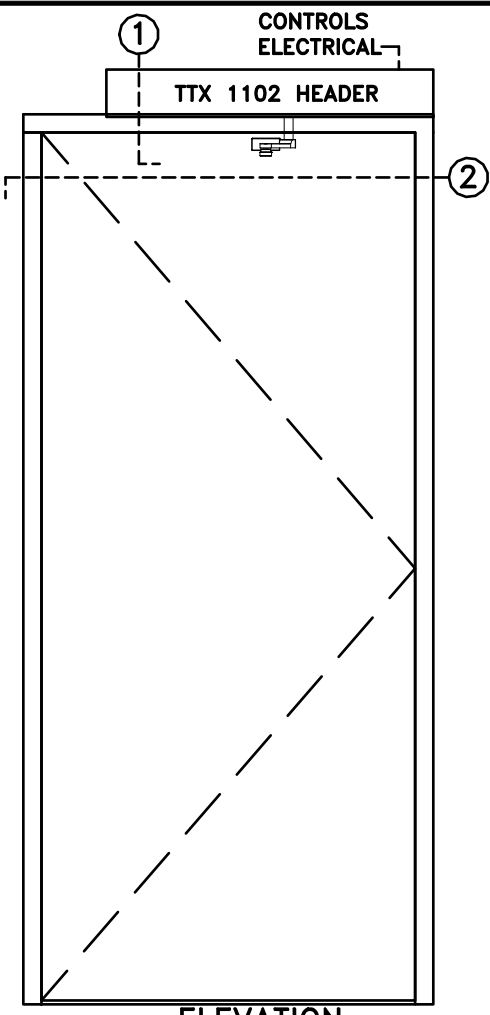

ELEVATION

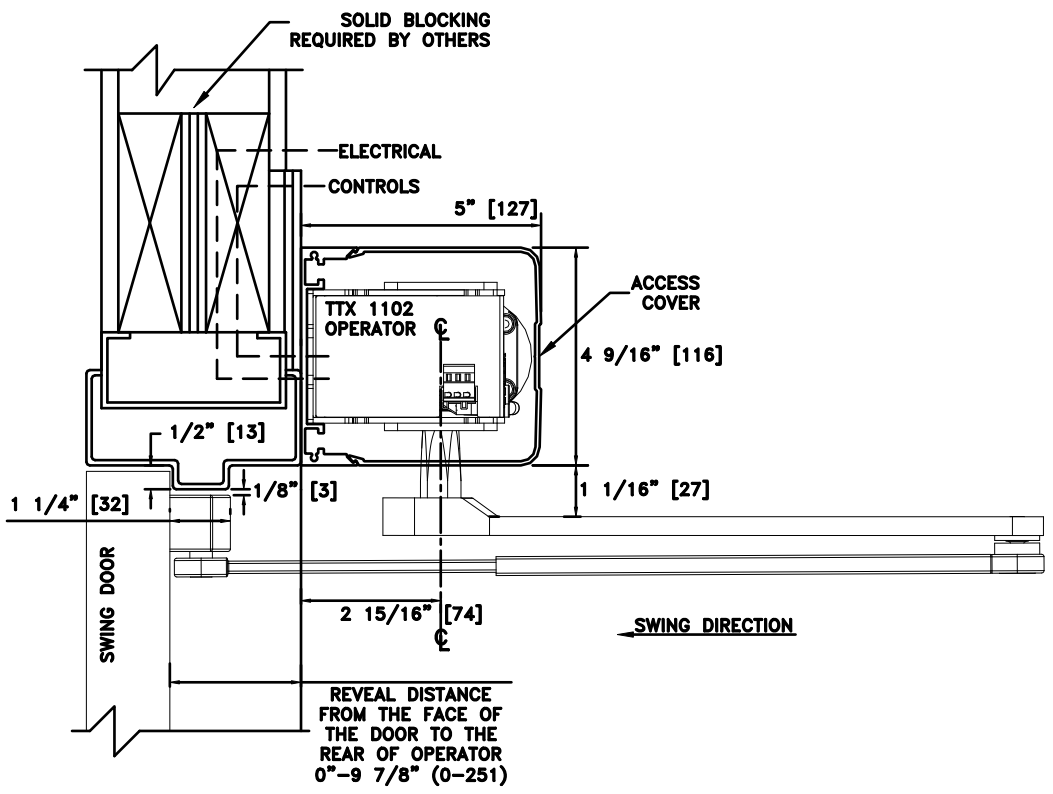

① VERTICAL SECTION

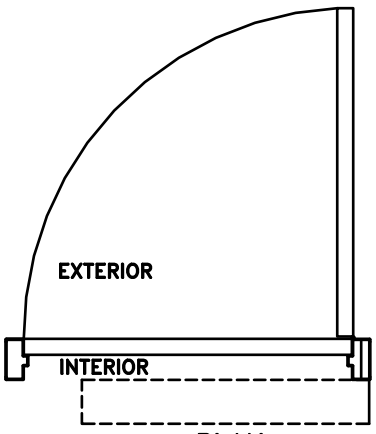

PLAN

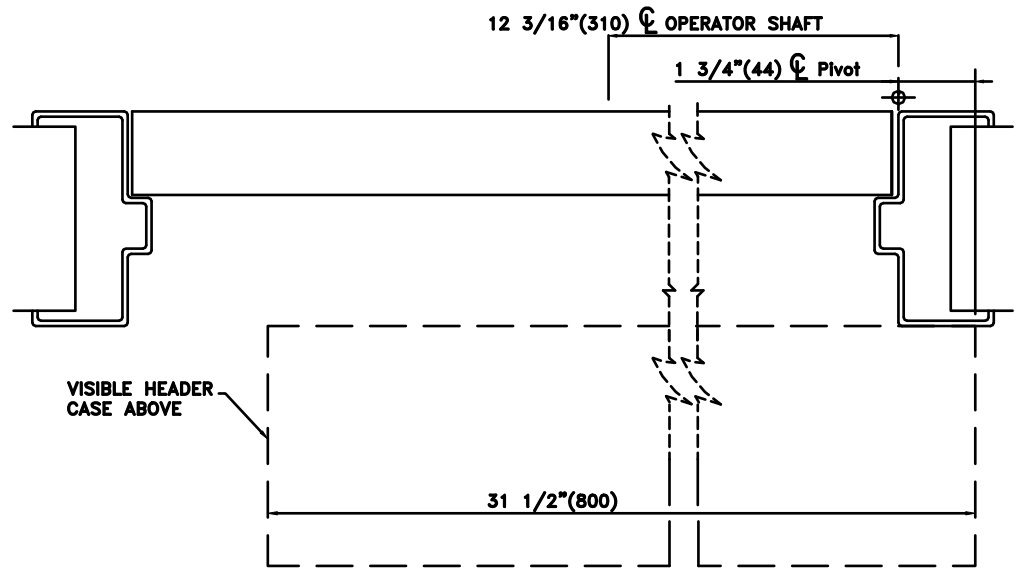

② HORIZONTAL SECTION

- NOTES:  
 1. DETAILS NOT TO SCALE.  
 2. ELECTRICAL REQUIREMENTS:  
 120VAC, 5AMPS MIN. TO OPERATOR BY ELECTRICAL CONTRACTOR.  
 3. DOORS, FRAMES AND HARDWARE BY OTHERS.  
 4. 32" CLEAR DOOR OPENING REQUIRED TO MEET A.D.A. REQUIREMENTS.  
 5. DOORS MUST BE NON-LATCHED FOR PROPER OPERATION.  
 6. OPERATOR HEADER IS AVAILABLE FOR FULL WIDTH DOOR APPLICATIONS.