

JOB NAME: _____ DATE: _____
 DOOR LOCATION: _____ DOOR NO: _____ SHEET _____ OF _____

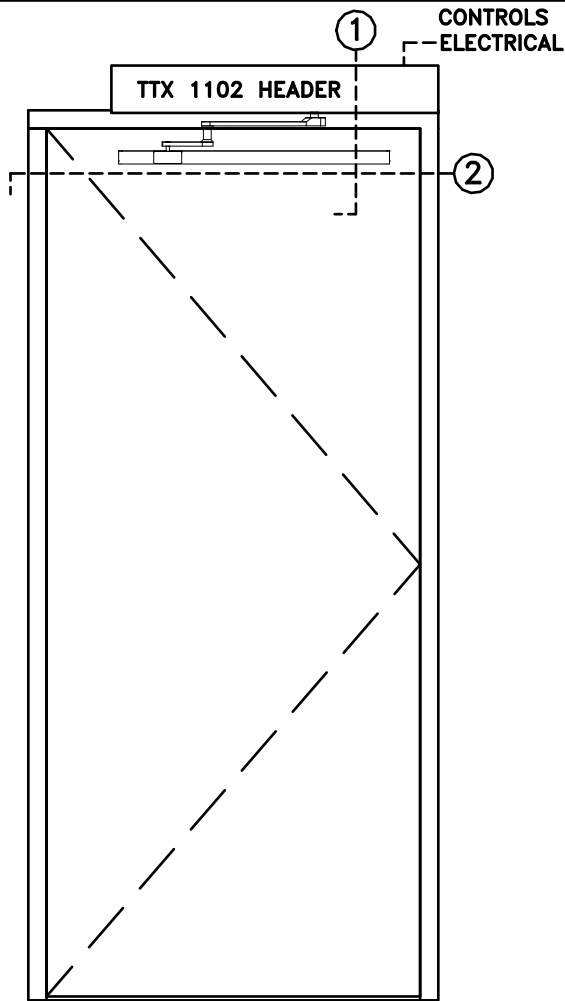

ELEVATION

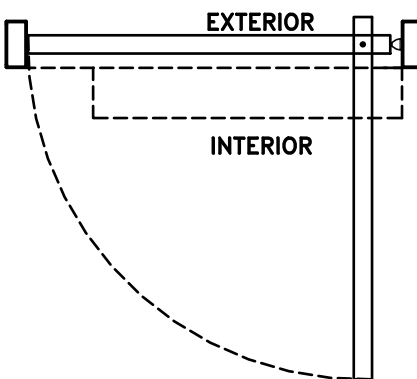

PLAN

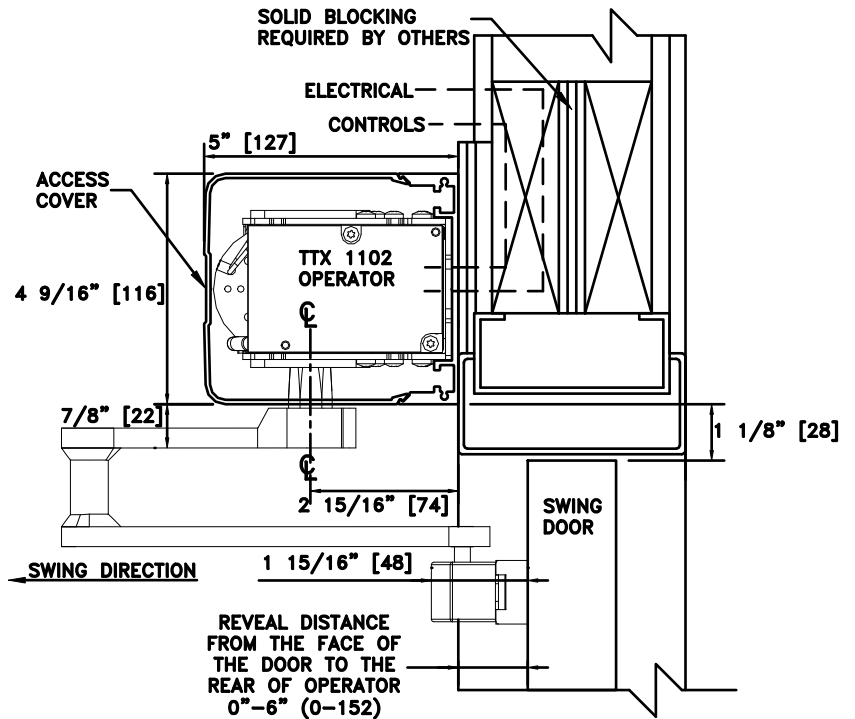

① VERTICAL SECTION

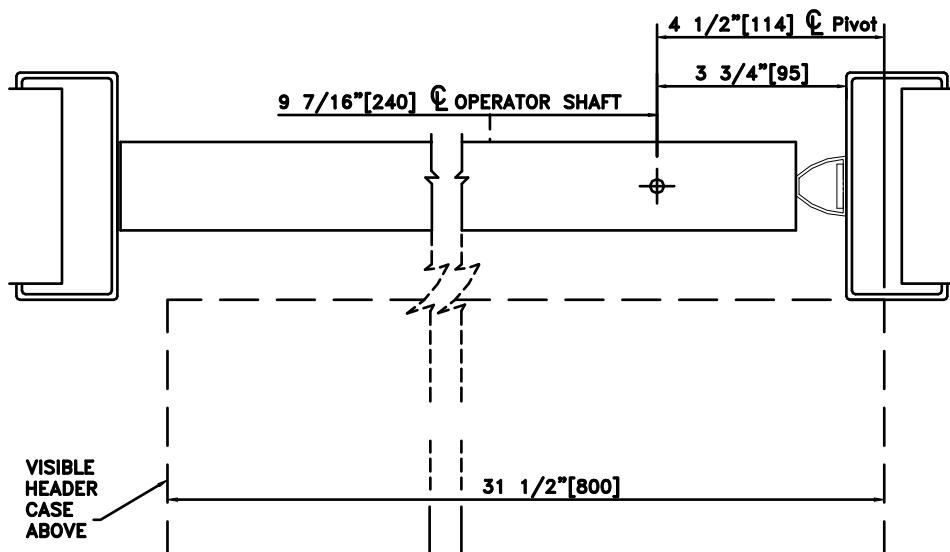

② HORIZONTAL SECTION

NOTES:

1. DETAILS NOT TO SCALE.
2. ELECTRICAL REQUIREMENTS:
120VAC, 5AMPS MIN. TO OPERATOR BY ELECTRICAL CONTRACTOR.
3. DOORS, FRAMES AND HARDWARE BY OTHERS.
4. 32" CLEAR DOOR OPENING REQUIRED TO MEET A.D.A. REQUIREMENTS.
5. DOORS MUST BE NON-LATCHED FOR PROPER OPERATION.
6. OPERATOR HEADER IS AVAILABLE FOR FULL WIDTH DOOR APPLICATIONS.