

DUAL INDEPENDENT OPERATION W/CONTINUOUS HEADER, VISIBLE R.H. INSWING, R.H. OUTSWING, BUTT HUNG AND OFFSET PIVOT APPLICATION

JOB NAME: \_\_\_\_\_ DATE: \_\_\_\_\_  
 DOOR LOCATION: \_\_\_\_\_ DOOR NO: \_\_\_\_\_ SHEET \_\_\_\_\_ OF \_\_\_\_\_

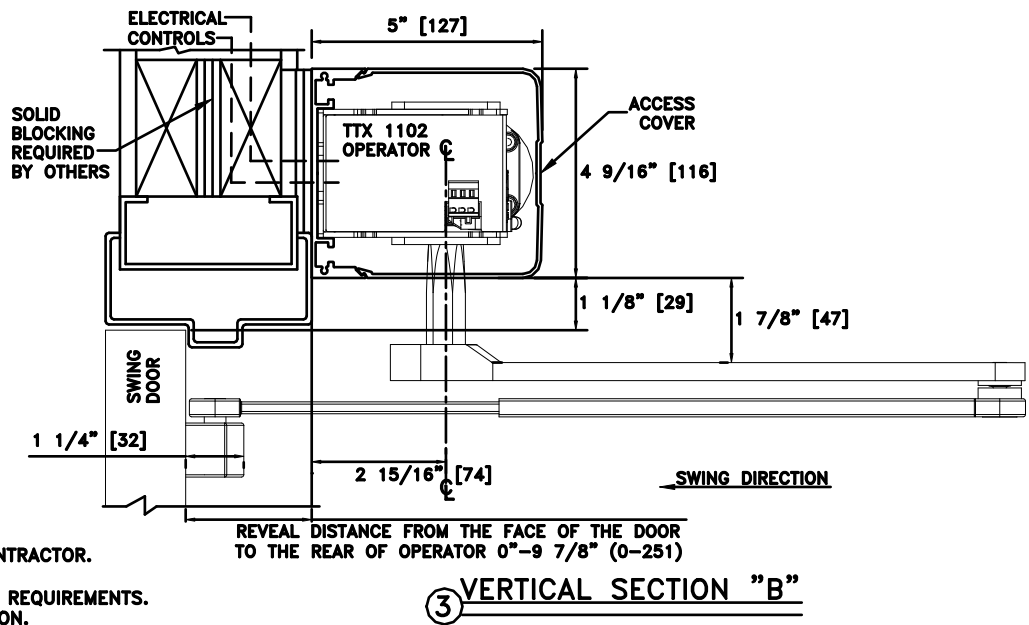
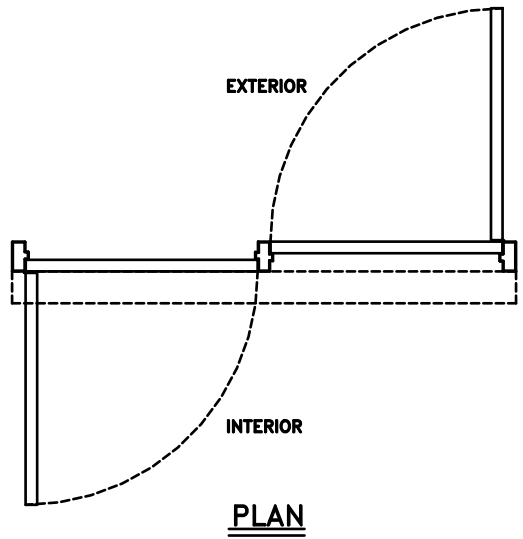
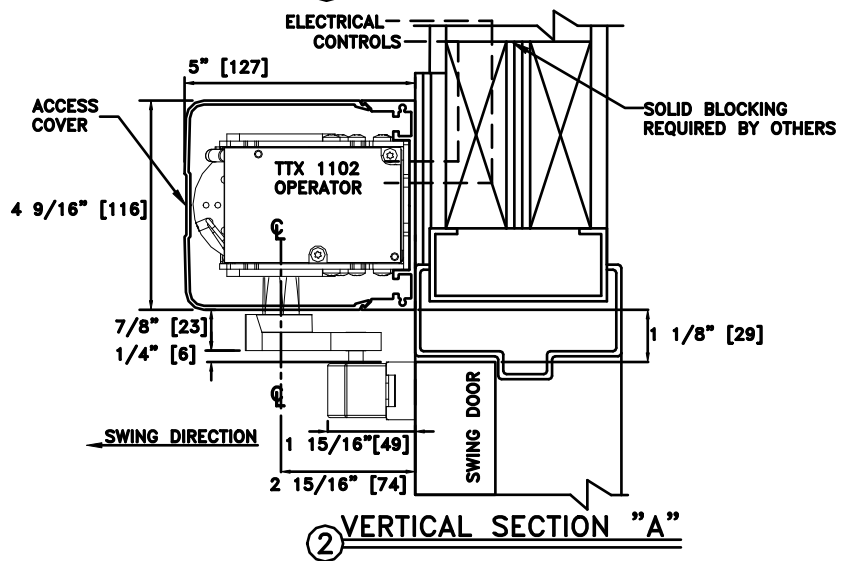
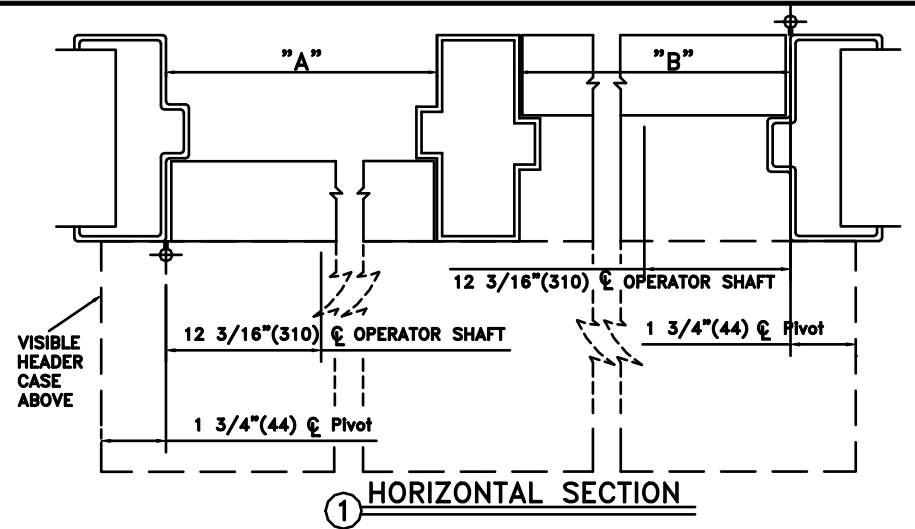
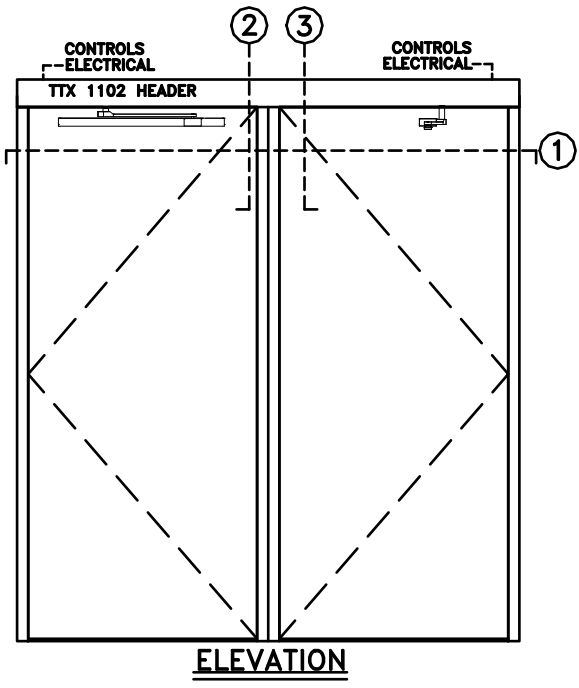

- NOTES:  
 1. DETAILS NOT TO SCALE.  
 2. ELECTRICAL REQUIREMENTS:  
 120VAC, 5AMPS MIN. TO OPERATOR BY ELECTRICAL CONTRACTOR.  
 3. DOORS, FRAMES AND HARDWARE BY OTHERS.  
 4. 32" CLEAR DOOR OPENING REQUIRED TO MEET A.D.A. REQUIREMENTS.  
 5. DOORS MUST BE NON-LATCHED FOR PROPER OPERATION.

REVEAL DISTANCE FROM THE FACE OF THE DOOR TO THE REAR OF OPERATOR 0"-9 7/8" (0-251)