

ITEM	QTY	EQUIPMENT LISTING	ITEM	QTY	EQUIPMENT LISTING
A	1	DOUBLE WALL FIBERGLASS STORAGE TANK	K	1*	FILL CAP & ADAPTER
B	-	XERXES PRECAST CONCRETE DEADMEN SYSTEM	L	1*	SCH 80 PVC INLET PIPING WITH SANITARY TEE, CAP & ADAPTER
C	-	FIBERGLASS HOLD DOWN STRAP WITH TURNBUCKLE ASSY.	M	1	4" DIA FLANGED & GUSSETED DOWN PIPE PUMPOUT NOZZLE
D	1	DRY MONITORING SYSTEM	N	3*	SMALL ROUND MANHOLE
E	1	42" DIA SW FIBERGLASS CONTAINMENT COLLAR	Q	1*	4" SENSOR CAP
F	1	42" DIA FIBERGLASS ROUND SW CONTAINMENT SUMP WITH 39" DIA WATERTIGHT TOP	P	1*	SCH 80 PVC PIPE WITH FLANGED ADAPTER
G	1*	LEVEL PROBE	Q	1*	SINGLE WALL VENT PIPING
H	1*	DRY MONITOR SENSOR			
I	1*	LARGE ROUND MANHOLE			
J	1	4" DIA FLANGED & GUSSETED INLET NOZZLE			

NOTE: * SUPPLIED BY OTHERS

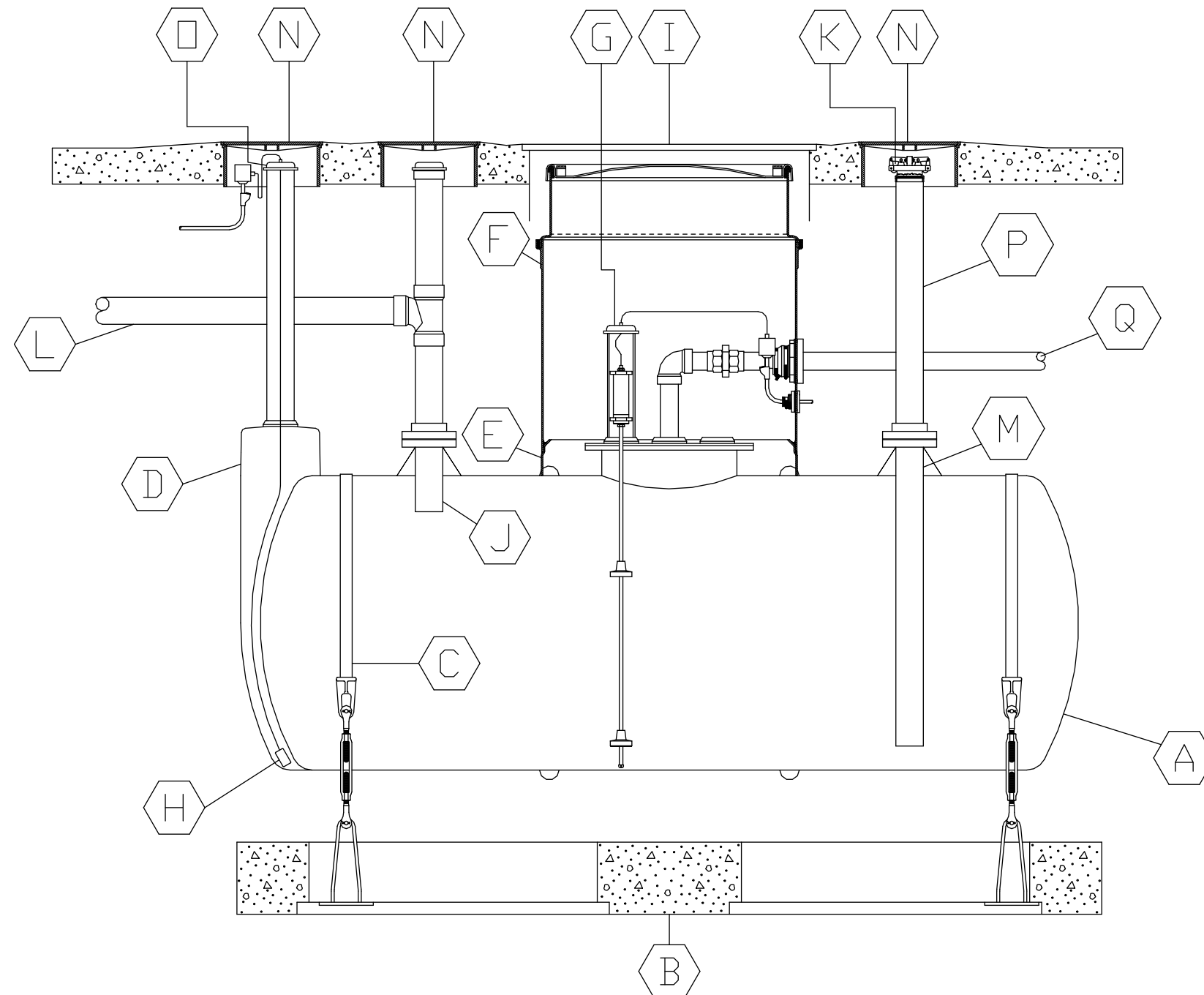

INDUSTRIAL
WASTEWATER

This drawing is for illustrative purposes only.
Consult with an engineer for specific applications.

XERXES[®]
a zcl company

TITLE DOUBLE-WALL
HOSPITAL EMERGENCY DECONTAMINATION
WATER STORAGE TANK

DATE 9-14 DR. NO. S20-314-00