

ITEM	QTY	EQUIPMENT LISTING	ITEM	QTY	EQUIPMENT LISTING	ITEM	QTY	EQUIPMENT LISTING
A	1	DOUBLE WALL FIBERGLASS STORAGE TANK	G	1*	DEF DISPENSER	N	1*	2" PRESSURE/VACUUM TANK VENT CAP
B	-	XERXES PRECAST CONCRETE DEADMEN SYSTEM	H	1*	STAINLESS STEEL REMOTE FILL BOX	O	1*	2" SCH 40 STAINLESS STEEL PIPE
C	-	FIBERGLASS HOLD DOWN STRAP WITH TURNBUCKLE ASSY.	I	1*	VERTICAL IMMERSION PUMP	P	1*	DISPENSER SUMP
D	1	DRY PROBE MONITORING SYSTEM	J	1*	CONTINUOUS MONIOTORING INVENTORY & LEAK DETECTION PANEL	Q	1*	42" MANHOLE
E	1	42" DIA FIBERGLASS CONTAINMENT COLLAR	K	2*	PVC RISER	R	2*	18" MANHOLE
F	1	42" DIA FIBERGLASS 8 SIDED SW CONTAINMENT SUMP WITH 32" DIA WATERTIGHT TOP	L	1*	TANK INVENTORY GAUGE	S	1*	PUMP CONTROL PANEL
			M	1*	HDPE EXTENSION TO TOP OF TANK			

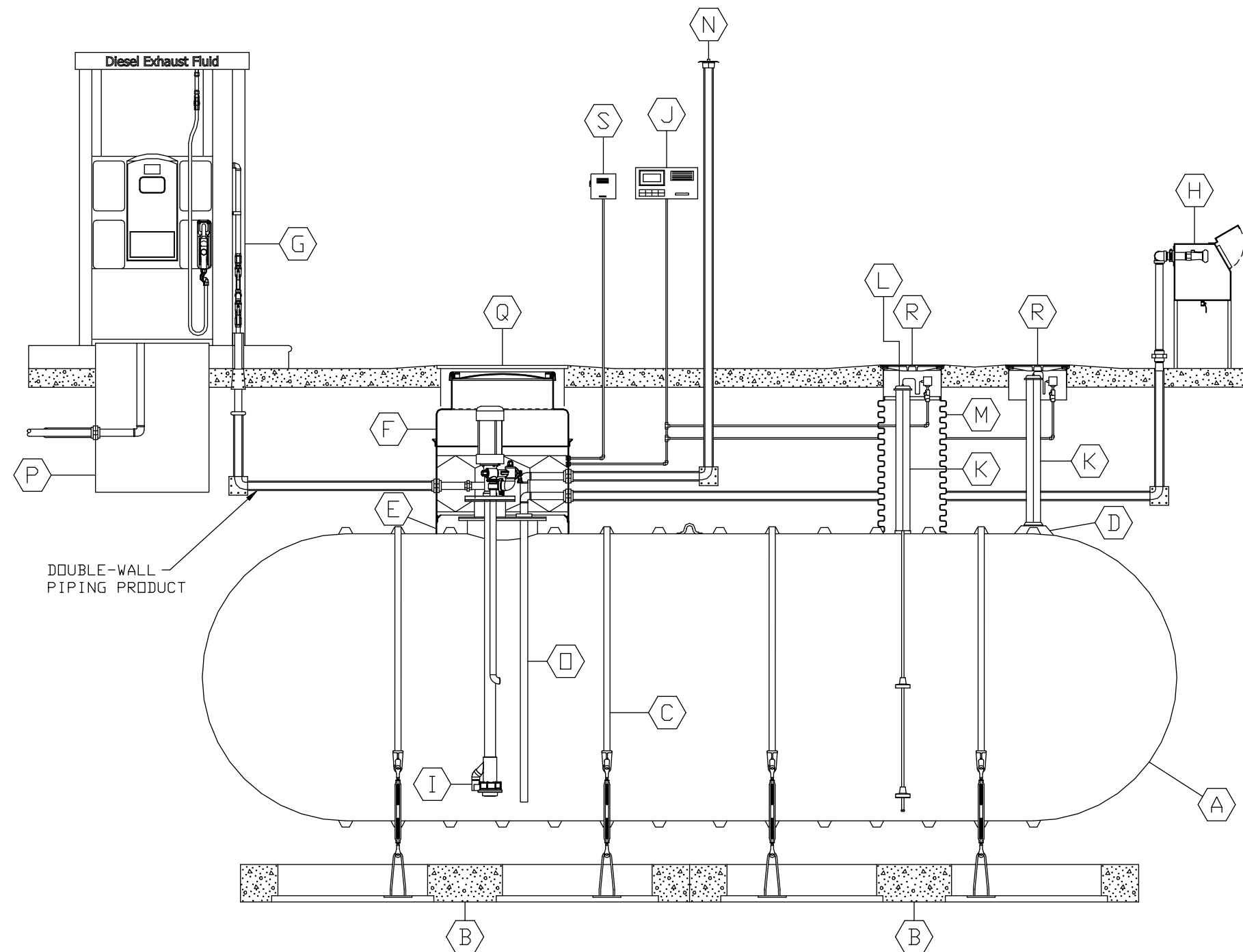

NOTE: * SUPPLIED BY OTHERS

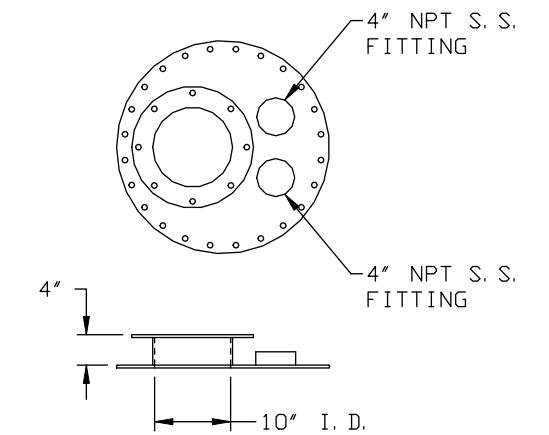

SPECIAL S. S. COVER DETAIL

<i>DEF</i>	
This drawing is for illustrative purposes only. Consult with an engineer for specific applications.	
XERXES [®] a ZCL company	
TITLE DOUBLE-WALL DEF TANK WITH VERTICAL IMMERSION PUMP	
DATE 3-14	DR. NO. S20-513-00