

ITEM	QTY	EQUIPMENT LISTING	ITEM	QTY	EQUIPMENT LISTING	ITEM	QTY	EQUIPMENT LISTING
A	1	DOUBLE WALL FIBERGLASS STORAGE TANK	J	1*	LARGE ROUND MANHOLE	T	1*	DOUBLE WALL PRODUCT SUPPLY PIPING
B	-	XERXES PRECAST CONCRETE DEADMEN SYSTEM	K	1*	FIVE GALLON SPILL FILL MANHOLE	U	2*	FLEXIBLE CONNECTOR
C	-	FIBERGLASS HOLD DOWN STRAP WITH TURNBUCKLE ASSY.	L	1*	FILL CAP	V	2*	FLEXIBLE CONNECTOR BOOT
D	1	HYDROSTATIC MONITORING SYSTEM	M	1*	FILL ADAPTER	W	1*	STAGE 1 VAPOR RECOVERY MANHOLE
E	1	42" DIA FIBERGLASS CONTAINMENT COLLAR	N	1*	PRODUCT LABEL MARKER	X	1*	STAGE 1 VAPOR CAP
F	1	42" DIA FIBERGLASS 8 SIDED SW CONTAINMENT SUMP WITH 32" DIA WATERTIGHT TOP	O	1*	OVERFILL PREVENTION VALVE	Y	1*	STAGE 1 VAPOR CHECK VALVE ADAPTER
G	1*	LEVEL PROBE	P	1*	MONITORING MANHOLE	Z	1*	EXTRACTOR ASSEMBLY
H	1*	DISTINGUISHING LEAK SENSOR	Q	1*	4" SENSOR CAP	AA	1*	SINGLE WALL STAGE 2 VAPOR RECOVERY PIPING
I	1*	HYDROSTATIC MONITOR SENSOR	R	1*	SUCTION SUPPLY INSTALLED W/ DOUBLE TAP BUSHING			
			S	1*	SINGLE WALL VENT PIPING			

NOTE: * SUPPLIED BY OTHERS

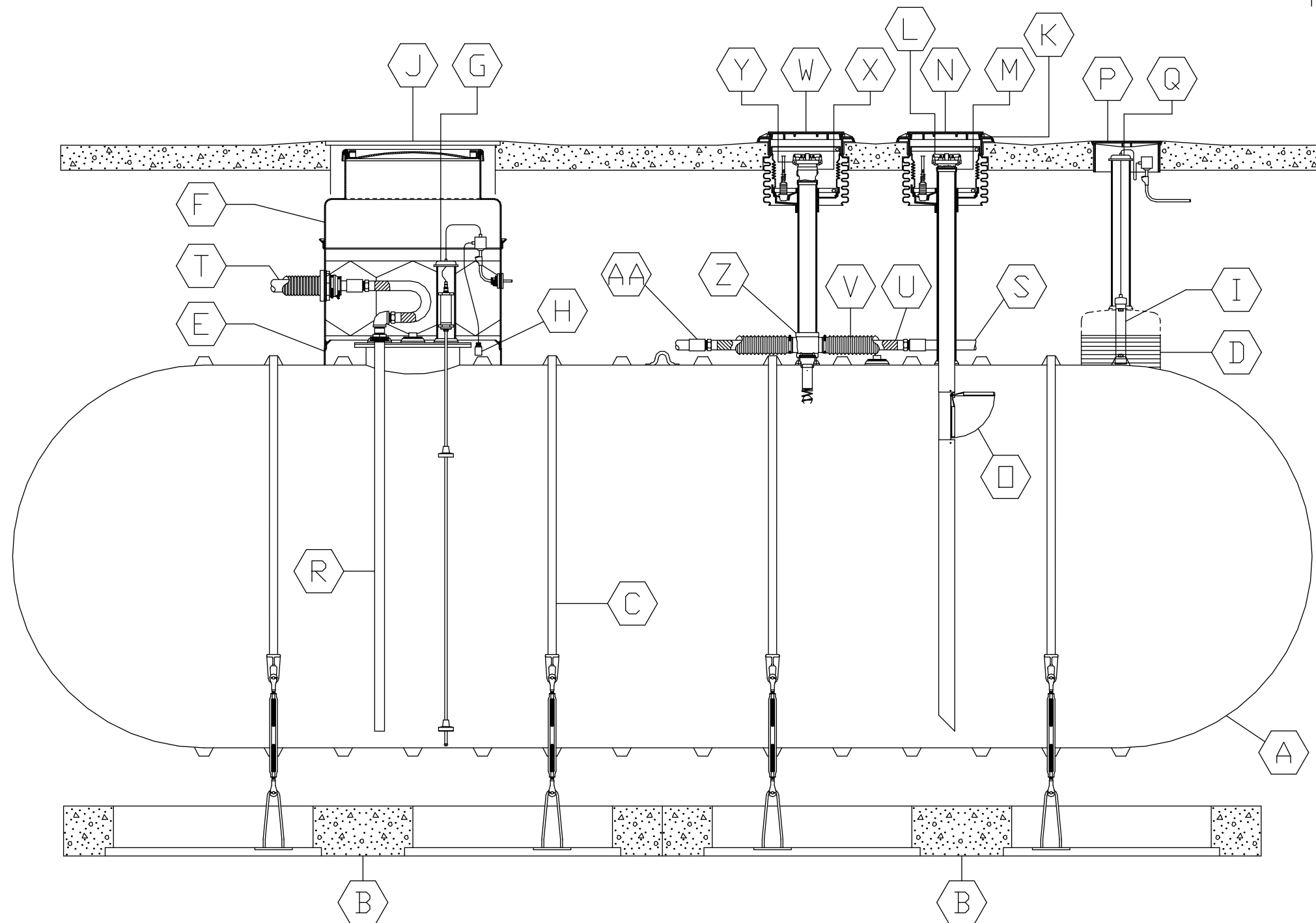

PETROLEUM

This drawing is for illustrative purposes only.
Consult with an engineer for specific applications.

XERXES[®]
a **ZCL** company

TITLE
DOUBLE-WALL SUCTION PIPING
STAGE 2 VAPOR RECOVERY

DATE 3-14 DR. NO. S20-509-01