

ITEM	QTY	EQUIPMENT LISTING	ITEM	QTY	EQUIPMENT LISTING
A	1	DOUBLE WALL FIBERGLASS STORAGE TANK	K	1*	FIVE GALLON SPILL FILL MANHOLE
B	-	XERXES PRECAST CONCRETE DEADMEN SYSTEM	L	1*	FILL CAP
C	-	FIBERGLASS HOLD DOWN STRAP WITH TURNBUCKLE ASSY.	M	1*	FILL ADAPTER
D	1	HYDROSTATIC MONITORING SYSTEM	N	1*	4" x 3" x 3" DOUBLE TAPPED BUSHING
E	1	42" DIA FIBERGLASS CONTAINMENT COLLAR	O	1*	BALL FLOAT
F	1	42" DIA FIBERGLASS 8 SIDED SW CONTAINMENT SUMP WITH 32" DIA WATERTIGHT TOP	P	1*	MONITORING MANHOLE
G	1*	LEVEL PROBE	Q	1*	4" SENSOR CAP
H	1*	DISTINGUISHING LEAK SENSOR	R	1*	USED OIL DRAIN W/ DOUBLE TAPPED BUSHING
I	1*	HYDROSTATIC MONITOR SENSOR	S	1*	SINGLE WALL VENT PIPING
J	1*	LARGE ROUND MANHOLE	T	1*	DOUBLE WALL PIPING W/ FLEX CONNECTOR
			U	1*	EXTRACTOR ASSEMBLY

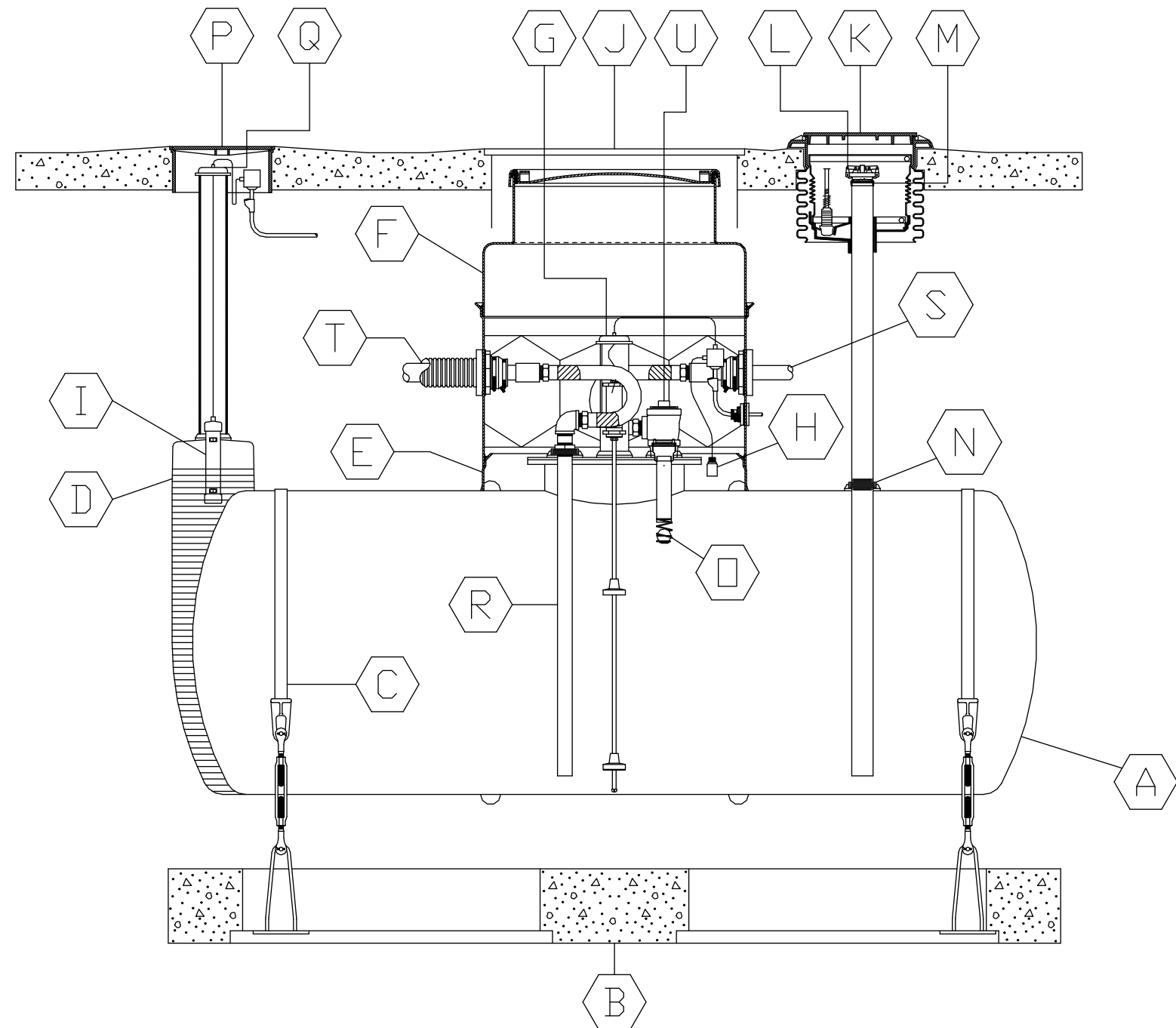

NOTE: \* SUPPLIED BY OTHERS

*PETROLEUM*

This drawing is for illustrative purposes only.  
Consult with an engineer for specific applications.

**XERXES**<sup>®</sup>  
a **ZCL** company

TITLE  
DOUBLE-WALL  
WASTE OIL STORAGE TANK

DATE 3-14 DR. NO. S20-510-01