

XYPEX PROJECT SPECIFICATIONS & SCHEMATIC DRAWINGS

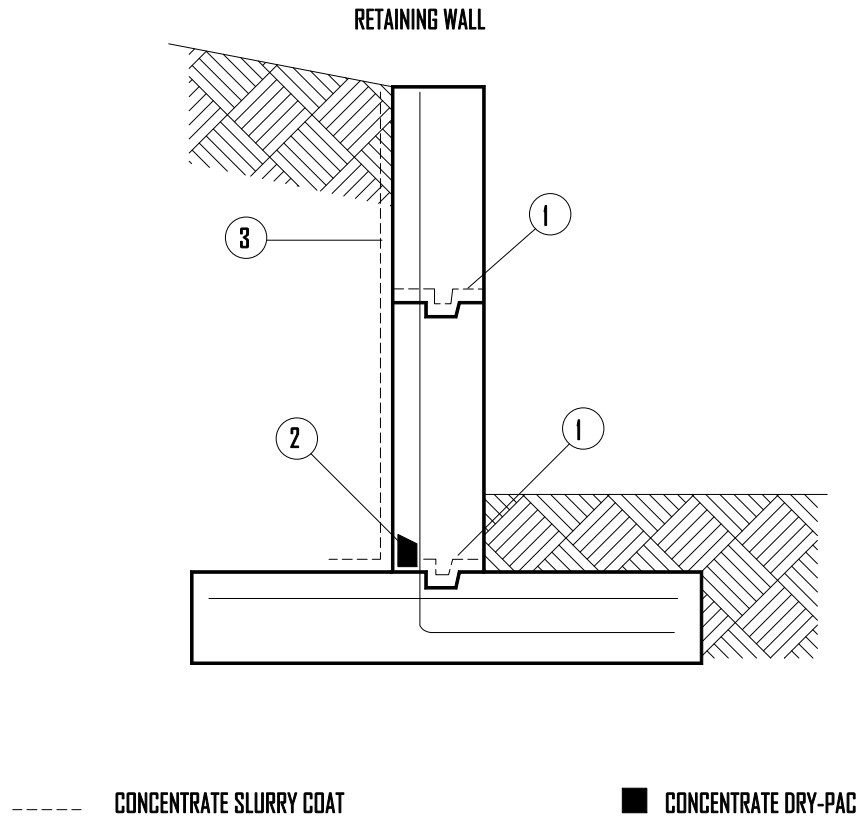

① BETWEEN POURS, APPLY XYPEX CONCENTRATE SLURRY TO JOINT SURFACES AT THE RATE OF 2.0 LB./SQ. YD. (1.0 KG/M²)

② IN SEALING STRIP, APPLY ONE SLURRY COAT OF XYPEX CONCENTRATE AT THE RATE OF 1.5 LB./SQ. YD. (0.8 KG/M²). THEN FILL SLOT TO SURFACE WITH XYPEX CONCENTRATE IN DRY-PAC FORM.

③ APPLY ONE COAT OF XYPEX CONCENTRATE TO WALL FACE AND OVER SEALING STRIP AT THE RATE OF 1.5 LB./SQ. YD. (0.8 KG/M²)

SCHEMATIC DIAGRAM SHOWS XYPEX APPLICATION ONLY AND DOES NOT DEPICT THE STANDARD REQUIREMENTS FOR WATERSTOPS OR EXPANSION JOINT SEALANTS.

THE SPECIFIER CAN CONSIDER THE ALTERNATIVE USE OF XYPEX DRY SHAKE OR XYPEX ADMIX, WHERE APPLICABLE.

REFER TO STANDARD SPECIFICATIONS FOR FURTHER INFORMATION.