

XYPEX PROJECT SPECIFICATIONS & SCHEMATIC DRAWINGS

SEWAGE PLANT DIGESTER TANK

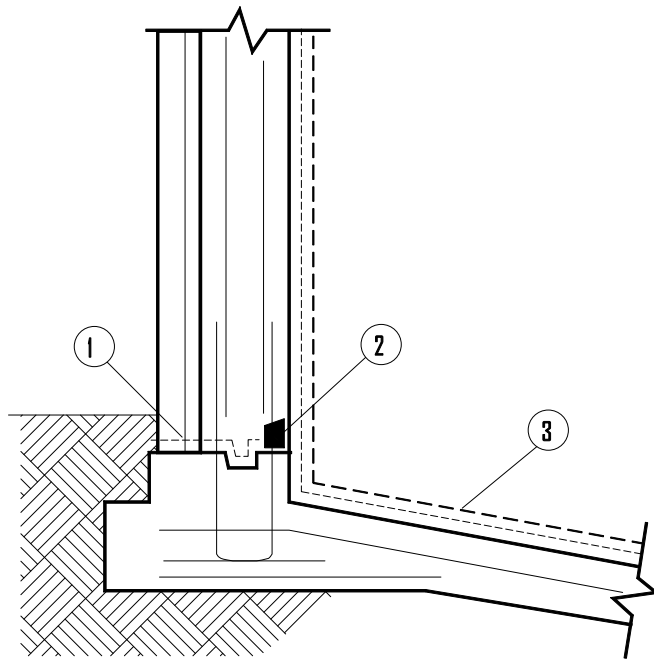

----- CONCENTRATE SLURRY COAT

■ CONCENTRATE DRY-PAC

----- MODIFIED SLURRY COAT

- ① BETWEEN POURS, APPLY XYPEX CONCENTRATE SLURRY TO ALL JOINT SURFACES AT THE RATE OF 2.0 LB./SQ. YD. (1.0 KG/M²)
- ② IN SEALING STRIP, APPLY ONE COAT OF XYPEX CONCENTRATE AT THE RATE OF 1.5 LB./SQ. YD. (0.8 KG/M²), THEN FILL SLOT TO SURFACE WITH XYPEX CONCENTRATE IN DRY-PAC FORM.
- ③ TO ALL WALL AND SLAB SURFACES, APPLY ONE SLURRY COAT OF XYPEX CONCENTRATE AT THE RATE OF 1.25 TO 1.5 LB./SQ. YD. (0.65 TO 0.8 KG/M²). AFTER THE CONCENTRATE HAS SET, BUT WHILE IT IS STILL "GREEN", APPLY A COAT OF XYPEX MODIFIED AT THE RATE OF 1.25 TO 1.5 LB./SQ. YD. (0.65 TO 0.8 KG/M²)

SCHEMATIC DIAGRAM SHOWS XYPEX APPLICATION ONLY AND DOES NOT DEPICT THE STANDARD REQUIREMENTS FOR WATERSTOPS OR EXPANSION JOINT SEALANTS.

THE SPECIFIER CAN CONSIDER THE ALTERNATIVE USE OF XYPEX DRY SHAKE OR XYPEX ADMIX, WHERE APPLICABLE.

REFER TO STANDARD SPECIFICATIONS FOR FURTHER INFORMATION.