

XYPEX PROJECT SPECIFICATIONS & SCHEMATIC DRAWINGS

PRECAST CONCRETE MANHOLE

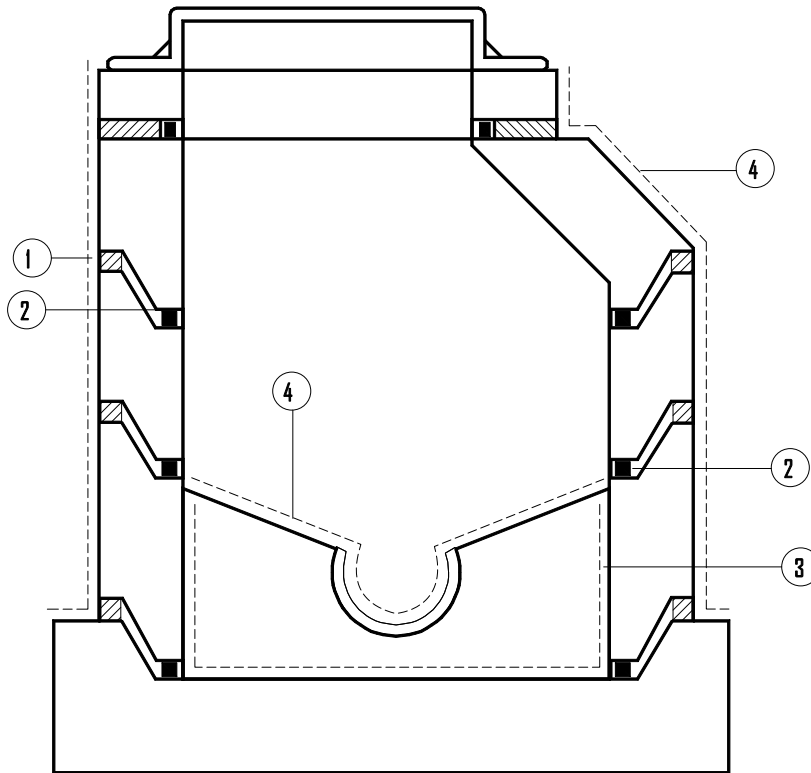

 PATCH'N PLUG

 CONCENTRATE SLURRY COAT

 CONCENTRATE DRY-PAC

- ① PLACE BLOCK IN JOINTS TO ALLOW 0.5 TO 0.75 INCH (13 MM TO 19 MM) GAP BETWEEN PRECAST SECTIONS. FILL EXTERIOR GAP WITH XYPEX PATCH'N PLUG GROUT.
- ② APPLY ONE SLURRY COAT OF XYPEX CONCENTRATE TO THE INTERIOR GAP AT THE RATE OF 1.5 LB./SQ. YD. (0.8 KG/M²), THEN FILL GAP TO SURFACE WITH XYPEX CONCENTRATE IN DRY-PAC FORM.
- ③ APPLY ONE SLURRY COAT OF XYPEX CONCENTRATE TO INTERIOR OF BOTTOM RING, FLOOR AND EXTERIOR WALLS AT THE RATE OF 1.25 TO 1.5 LB./SQ. YD. (0.65 TO 0.8 KG/M²)
- ④ AFTER PLACEMENT OF CONCRETE TROUGH, APPLY ONE SLURRY COAT OF XYPEX CONCENTRATE AT THE RATE OF 1.5 LB./SQ. YD. (0.8 KG/M²) TO ITS SURFACE.

SCHEMATIC DIAGRAM SHOWS XYPEX APPLICATION ONLY AND DOES NOT DEPICT THE STANDARD REQUIREMENTS FOR WATERSTOPS OR EXPANSION JOINT SEALANTS.

THE SPECIFIER CAN CONSIDER THE ALTERNATIVE USE OF XYPEX DRY SHAKE OR XYPEX ADMIX, WHERE APPLICABLE.

REFER TO STANDARD SPECIFICATIONS FOR FURTHER INFORMATION.