

PURGENVENT™

Model 7900AAV

QUALITY COMPONENTS FOR FIRE SPRINKLER SYSTEMS

Automatic Air Venting Valve

The AGF PURGENVENT Model 7900AAV Automatic Air Venting Valve is designed to remove excess air from wet pipe fire sprinkler systems to help mitigate internal pipe corrosion. NFPA 13 standard requires the addition of an air vent on all wet pipe fire sprinkler systems that utilize metallic pipe.

The PURGENVENT Model 7900AAV features a FM approved and UL listed 7900V automatic air vent that releases excess air while the system is in operation. It also includes an isolation valve, strainer, and purge valve with union and hose connection. The purge valve helps remove air from the system faster when filling, helps flush and clean the valve, and can be used as a vacuum break when draining the system. When being used as a vacuum break it helps drain the system faster and protects gaskets from being dislodged on other system components. AGF recommends installing the valve at the highest point in the system or at the end of system branch lines.

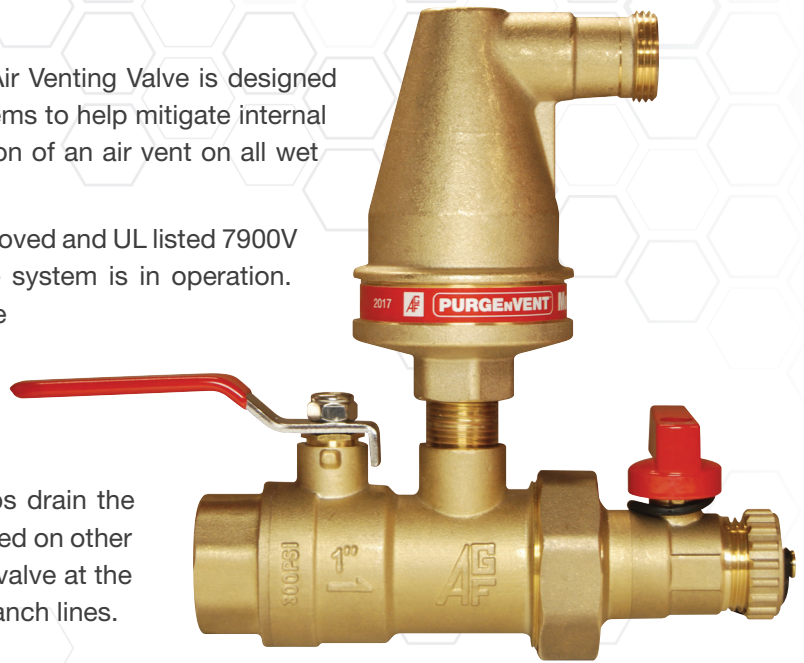

Features

- NFPA Compliant
- FM Approved and UL Listed 7900V Air Vent
- 175 PSI Rated
- Isolation Valve
- Internal Strainer
- Purge Valve with Union and Hose Connection
- System Drain Vacuum Break

Models

| Part Number |
|-------------|
| 7900AAV |

7900V Air Vent Advantages

1. Conical shape maximizes clearance and protects the venting valve from contamination.
2. Recessed venting valve prevents vent redundancy and protects it from damage.
3. Single float allows only vertical movement.
4. Bubble breaker acts as a secondary filter and maximizes air passage.

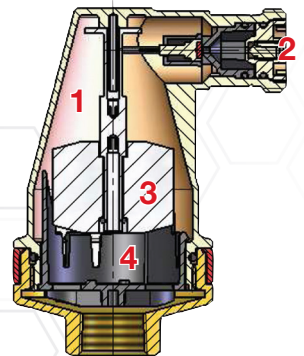

7610-2281 : 0500



Installation

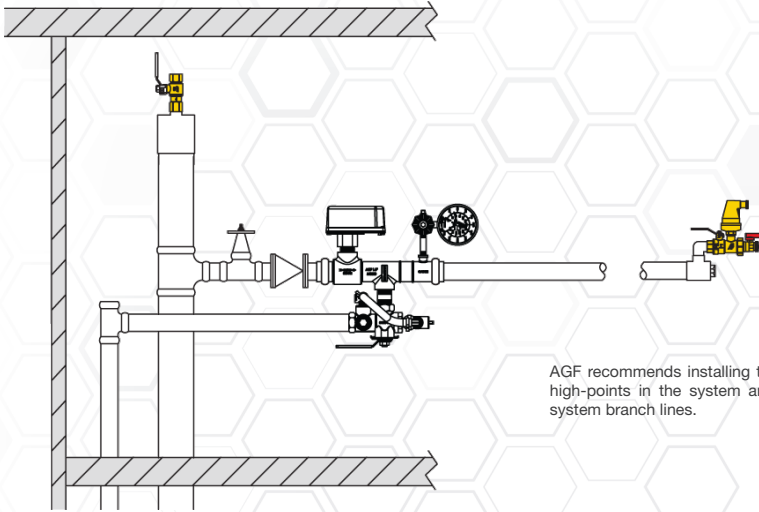

AGF recommends installing the M7900AAV at high-points in the system and at the end of system branch lines.

Dimensions

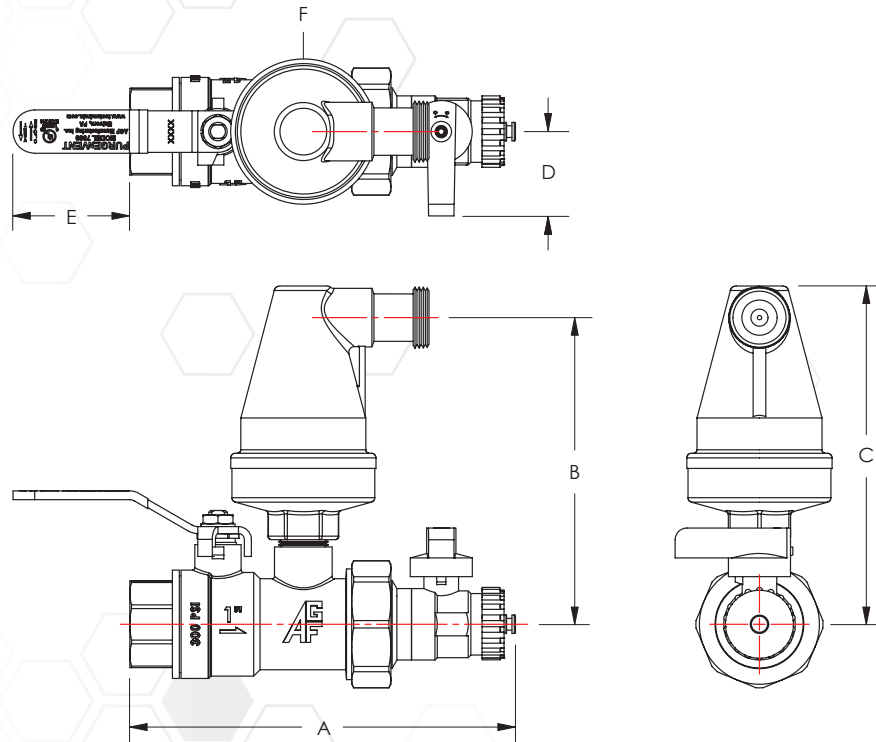

| A | B | C | D | E | F |
|--------------------|--------------------|--------------------|-------------------|---------------|--------------------|
| 6 5/8" (167 mm) | 5 1/4" (133 mm) | 5 3/4" (147 mm) | 1 1/2" (37 mm) | 2" (51 mm) | ø2 1/2" (63 mm) |

Sizes have been rounded to the highest millimeter

USA Patent #10391344 and Other Patents Pending

For use on wet fire sprinkler systems.

Valve Size

1"

Connections

- Isolation Valve Inlet..... 1" NPT
- Purge Valve Outlet..... Hose
- 7900V Vent Outlet..... 3/4" NPT

Installation Orientation

Horizontal with 7900V in Upright Position

Electrical Requirements

None

Materials

- Handle Steel
- Stem Rod Brass
- Ball.....C.P. Brass
- Body Brass
- Valve Seat.....PTFE
- StrainerStainless Steel
- 7900V Bronze

Rating

175 PSI

Compliance

- NFPA 13, 13D, & 13R
- NYC-BSA No. 720-87-SM

Approvals

- 7900V: UL/ULC (EX27596)
- 7900V: FM



7610-2281 : 0500



AGF Manufacturing Inc.
 100 Quaker Lane, Malvern, PA 19355
 Phone: 610-240-4900
 techsupport@agfmfg.com
www.agfmfg.com

Job Name: _____
Architect: _____
Engineer: _____
Contractor: _____