

Angled Coupled Standard Motorized No-Fascia Shade

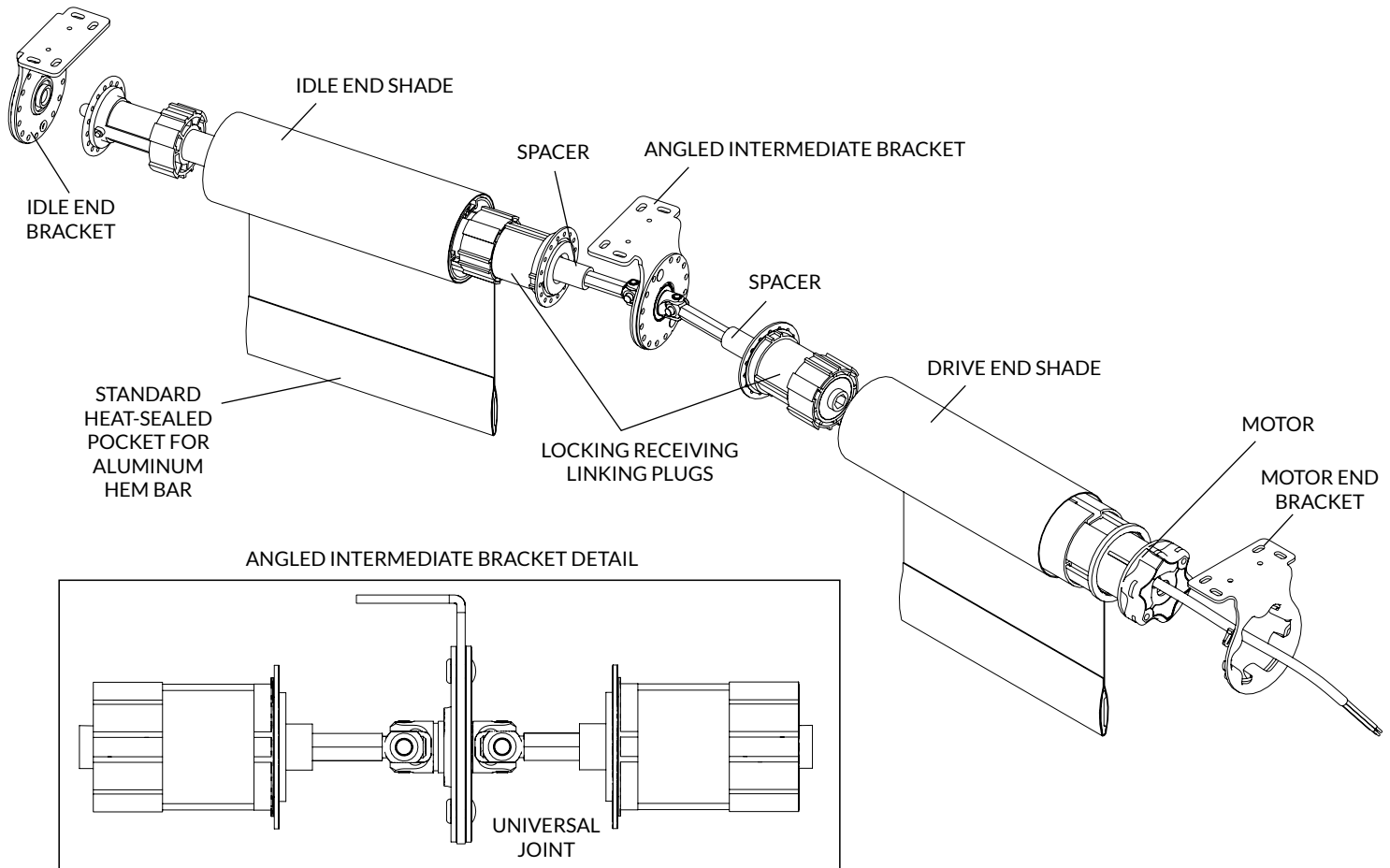

- Couple up to 3 bands to a maximum opening width of 20 feet, based on fabric selection and height within torque limitations.
- Shades are linked by an angled connector drive shaft with universal joint that can accommodate angles of 0° to 20° (+/- 10° per side) up to 6 Nm and 30° (+/- 15° per side) up to a 4 Nm of calculated system torque.
- Adjustable idle end and angled intermediate bracket allows shades to be leveled while in place.
- Brackets are top mount only.
- Roller tube is 2.45" T5 extruded aluminum engineered with a channel to accept fabric spline, making the shade panel easy to remove.
- Brackets are stamped steel and corrosion resistant. Available in powder coated white.
- Shades are raised and lowered by means of a line voltage AC motor.
- All motors come standard with a quick disconnect plug.
- Hem bar is extruded aluminum and completely enclosed in a heat-sealed hem pocket.
- Optional external fabric wrapped hem bar is available in a maximum width of 12 feet. Colors include white, clear anodized, and bronze.
- Limited lifetime warranty.