

DESCRIPTION

BMU are designed for permanent facade access for cleaning and maintenance on mid to high-rise buildings. This compact sized unit is capable of servicing buildings with heights up to 720 ft. (220 m).

The suspended platform is designed for two maintenance personnel with their ols and cleaning materials with a minimum capacity of 500 lbs (220 kg).

FUNCTION FEATURES

- a mobile traversing **BMU** with a hydraulic powered luffing boom **to a** maximum reach of 20 ft (6 m).
- electric **tirak**® hoists and controls
- a work platform is suspended from the **BMU** boom by four independent galvanized steel wire ropes
- track* for traversing

OPTIONAL FEATURES

- wireless control
- slewing of turret, to allow rotation of platform to in board position

* See technical sheet T4761.1 BMU Track

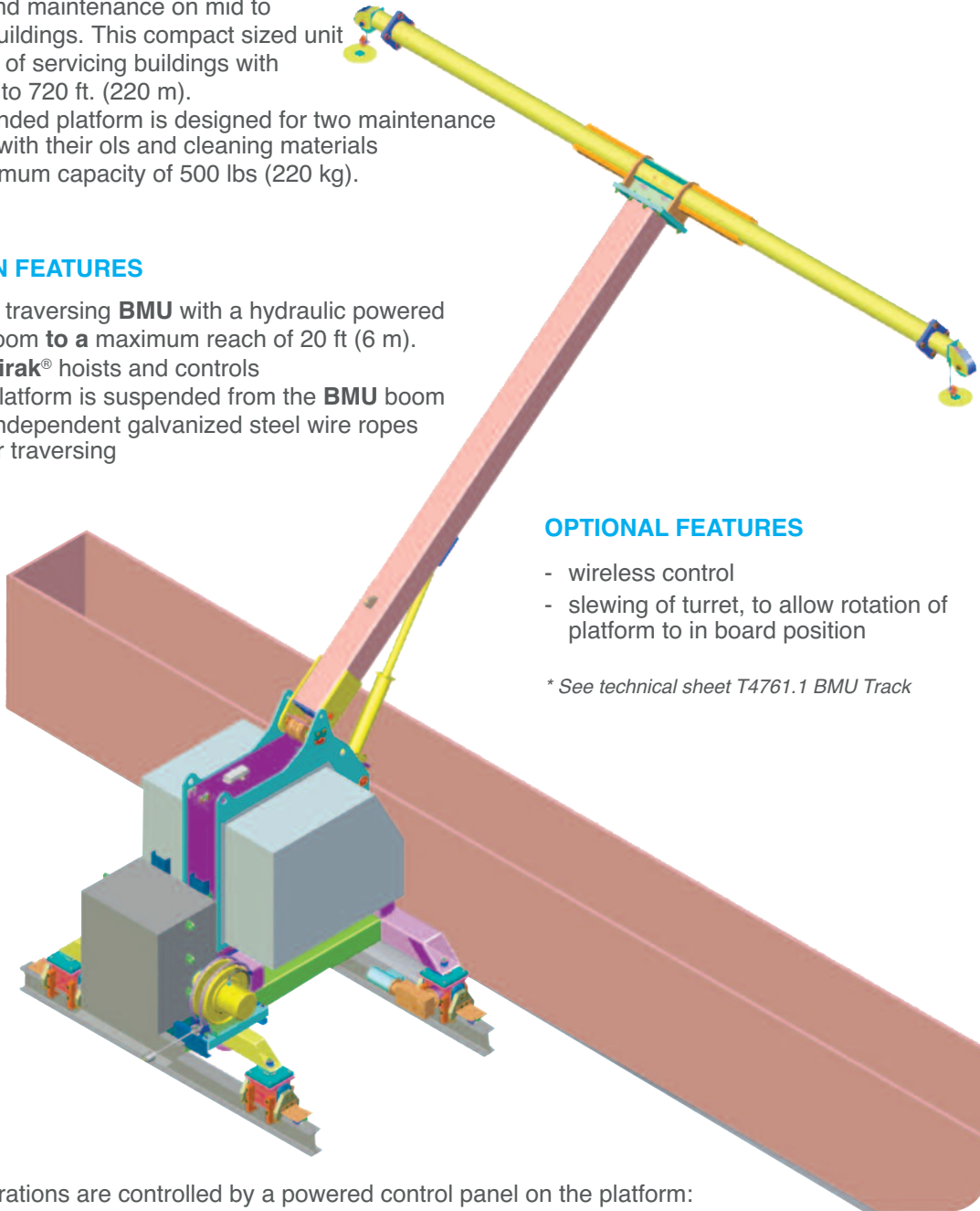

All the operations are controlled by a powered control panel on the platform:

- lifting and lowering the platform
- boom angle (luffing)
- traversing the trolley

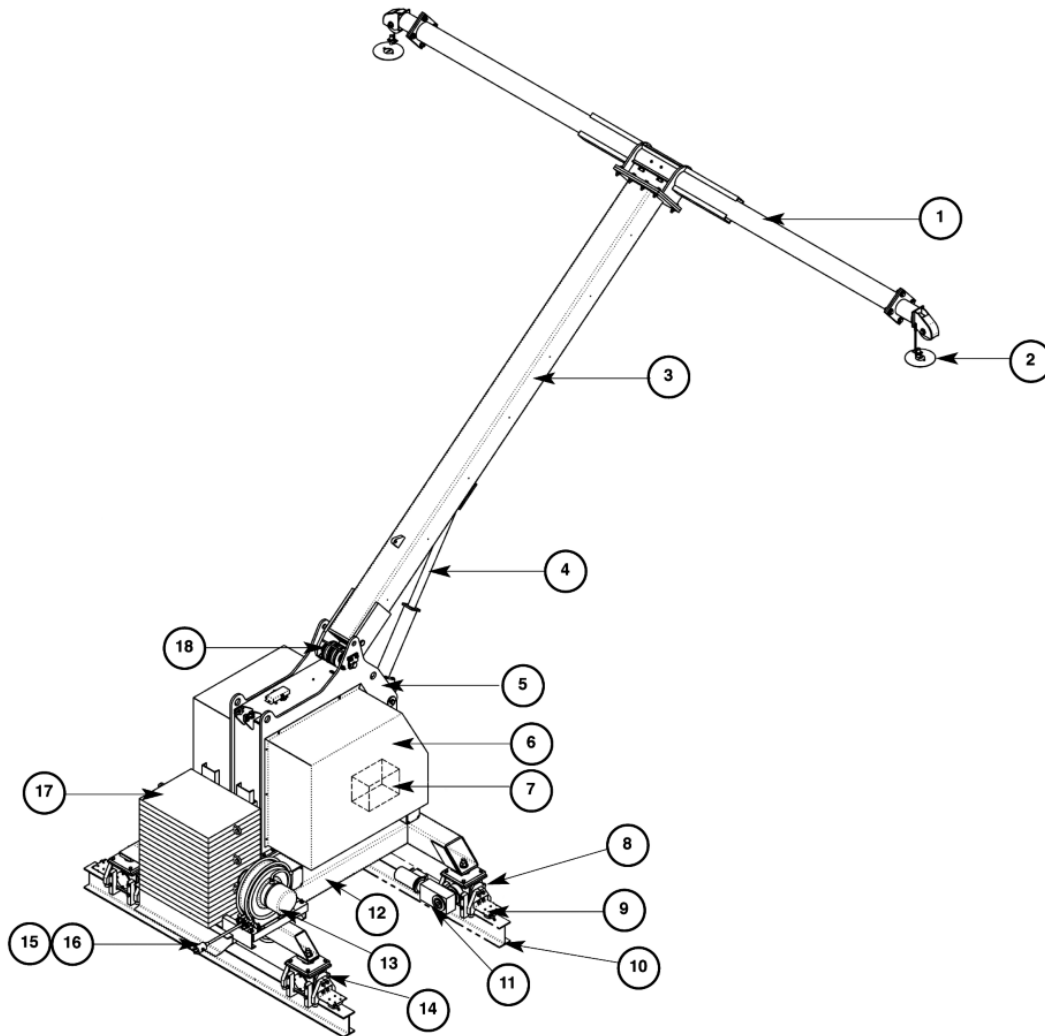

MAIN COMPONENTS OF A BMU

- | | |
|---|------------------------------------|
| 1. Cross Boom Assembly | 12. Carriage Assembly |
| 2. Upper Limit Switch | 13. Reel for Power Supply Cable |
| 3. Luffing Boom | 14. Rear Wheel Assembly |
| 4. Hydraulic Cylinder | 15. Power Supply Cable |
| 5. Cylinder Support Assembly | 16. Electrical Plug |
| 6. tirak® Box Assembly | 17. Counterweight |
| 7. Hydraulic Power Unit, 208v Single Ph | 18. Boom Shaft And Sheave Assembly |
| 8. Drive Wheel Assembly | |
| 9. Roof Car Wheel Sensor | |
| 10. BMU Track | Not Shown: |
| 11. Geared Motor with Brake | tirak® Hoist |
| | Work tracmod® Platform |

FRONT VIEW

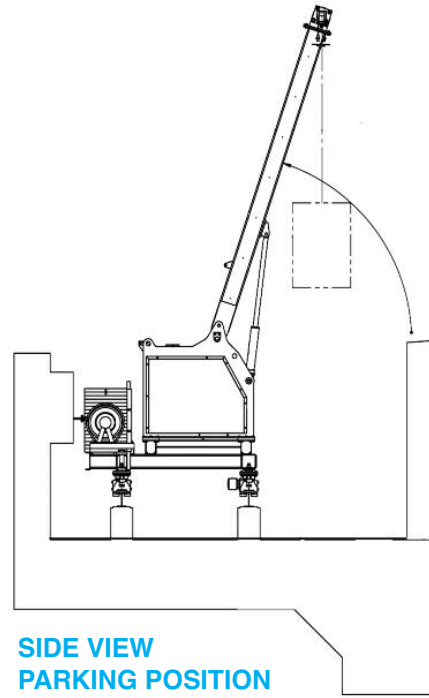
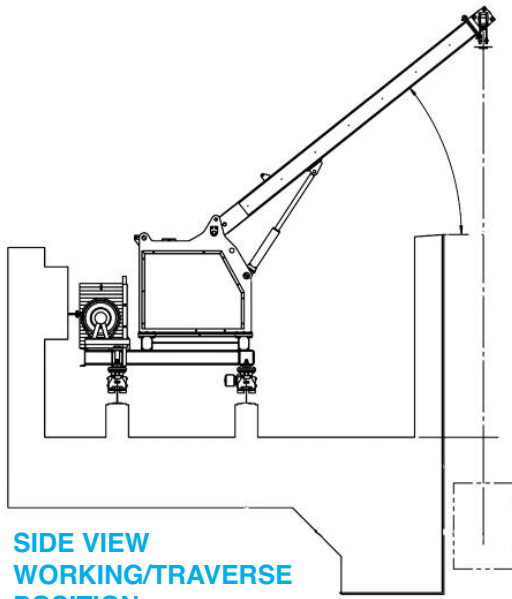
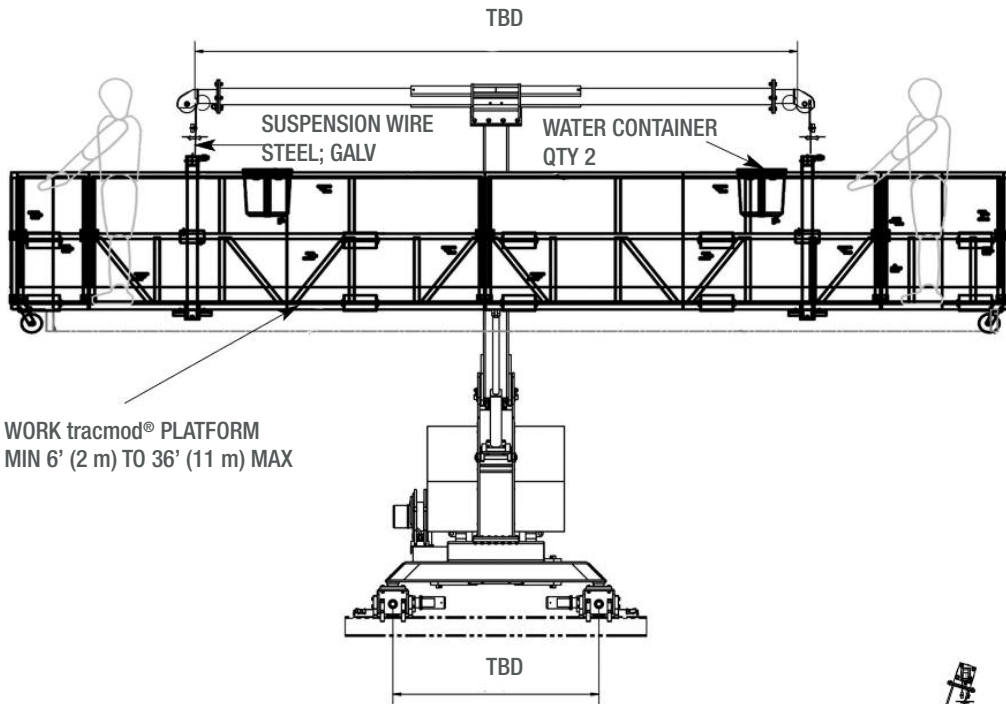

2. DESCRIPTION OF THE COMPONENTS

2.1 Traversing frame

The lower frame is constructed of galvanized rectangular steel tube. Four wheel assemblies are fitted to the frame. The 2 front wheels are powered and the two rear wheels are mounted on an articulated beam to ensure an even load distribution.

2.2 Traversing system

Traversing is powered by an electrical motor with a speed approximately 20 ft./min (6 m/min.) In general, only the two wheels nearest the building facade are powered. The Traversing Frame is guided along the track by guide wheels placed laterally on the wheel assemblies, whether 'L' shaped guide track (Fig. 4), or I-beam track (Fig. 5) is used.

Fig. 4 - Traversing on concrete

Fig 5 - Traversing on rails track, with 'L' shaped guide rail

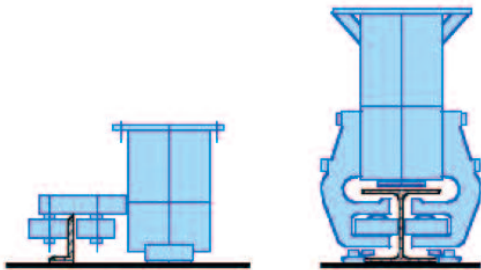

2.3 Lifting mechanism

The lifting mechanism is the tirak® electric traction hoist, especially designed for man-riding applications. The operation of the tirak® is based on the principle of pressure pulleys. The gripping of the wire rope in the pulley is achieved by a set of rollers, activated by a compression spring (Fig. 6).

2.4 Hydraulic system

A single hydraulic cylinder is used to operate the angle of the boom. Adjusting the boom angle determines the various working positions on the building, from upright (park position) to horizontal (maximum reach).

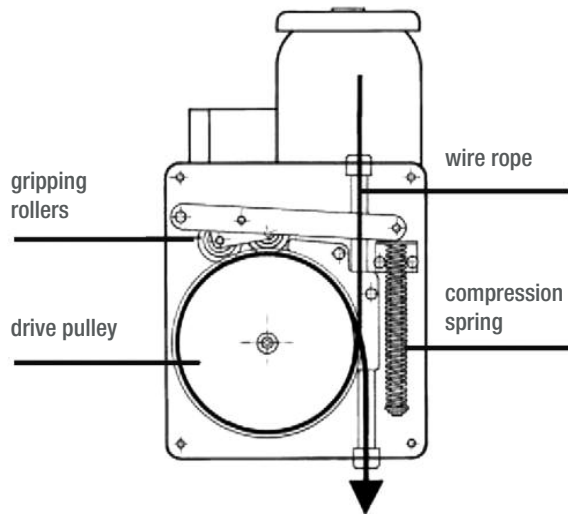

2.5 Electrical system

The electrical system consists of the following main items:

- a) On the building
 - the main switch, located on the roof
 - power supply points, 3-phase + ground, positioned along the track and protected by a 30 amp circuitbreaker (supplied by the customer).
- b) On the traversing frame
 - the power supply cable for connecting the roofcar frame to the power points. This cable is stored on a reel under the unit.
 - an electrical panel with a control box for the unit.
- c) On the platform
 - main control panel connected to the roofcar by a flexible cable.

2.6 Platform

Roofcars suspend a 'F-type platforms' as defined by US Federal OSHA (dual-line suspension). The platforms are driven by hoists on the roof unit, instead of on the platform. These work platforms are constructed of tubular aluminum, clad in perforated aluminum panels. Typical length is 10 ft. (3 m), however this may be increased to a maximum of 36 ft. if required. Typical minimum capacity is 500 lbs. (220 kg).